

Table Of Contents

| Section | Description | Page # |
|---------|---------------------------------------|--------|
| 7.1. | Micro SL Pump Module | 7-2 |
| 7.2. | Description | 7-2 |
| 7.3. | Operation | 7-2 |
| 7.3.1. | Piston/Cylinder Set | 7-2 |
| 7.4. | Installation | 7-3 |
| 7.5. | Options | 7-3 |
| 7.5.1. | Ceramic Size and Materials | 7-3 |
| 7.5.2. | Gland | 7-3 |
| 7.5.3. | Port Size | 7-3 |
| 7.6. | Maintenance | 7-3 |
| 7.6.1. | Preventative Maintenance | 7-3 |
| 7.6.2. | O-Rings | 7-4 |
| 7.6.3. | Assembly/Disassembly Procedures | 7-4 |
| 7.7. | Problem Guide | 7-7 |
| 7.7.1. | Piston Seized In The Cylinder | 7-7 |
| 7.8. | Specifications | 7-8 |
| 7.9. | Model Number | 7-8 |
| 7.10. | Illustrated Parts Breakdown | 7-8 |

7. MICRO SL PUMP MODULE

7.1. DESCRIPTION (Figure 7.1)

The Micro SL (Sanitary Linear) Pump Module, hereafter referred to as the Pump Module, is comprised of the following major components; a ceramic piston fabrication, a cylinder in a case and intake and discharge ports designed to accept a 1/4-28 or 5/16-28 male threaded fitting. The Pump Module is within the liquid path and is designed to be detached from the Actuator Module and completely disassembled for ease of cleaning, decontamination and sterilization. The Pump Module is designed to be used in conjunction with the 40-pitch Actuator Module. Installing this Pump Module on a 20-pitch Actuator Module will damage the Pump Module.

The ceramic material's mechanical and thermal stability allows the Pump Module to be sealed by virtue of a close running clearance between the piston and the cylinder bore. This means that no compliant dynamic seals are used eliminating a part requiring frequent replacement in traditional pump designs.

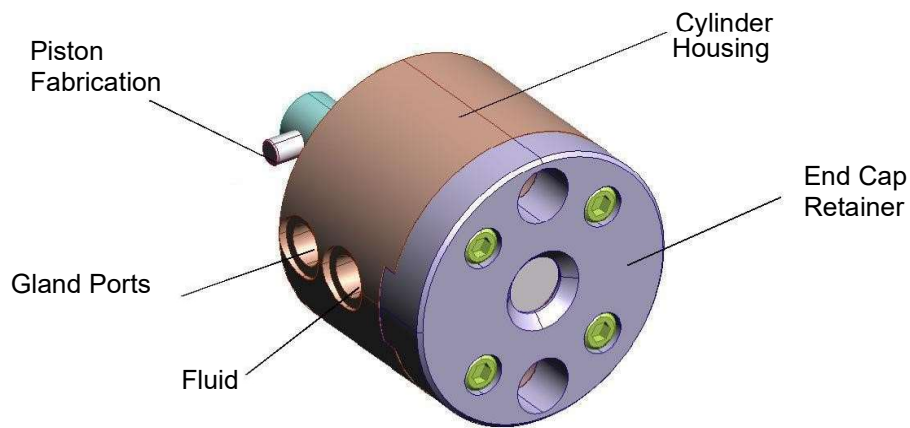

Figure 7.1 Micro SL Pump Module

7.2. OPERATION

The Pump Module is a piston/cylinder arrangement providing positive displacement. The Pump Module contains a ceramic piston that is selectively rotated and reciprocated by the Actuator Module. The piston is connected to the Actuator Module through a unilaterally flexible coupling located on the end of the Actuator Module's lead screw. The piston incorporates a flat on one end that provides valving of the pump to either the intake or discharge ports.

The piston's home position is with the piston flat aligned with the discharge port and retracted to fill the cylinder with liquid. The piston is pushed forward forcing the required amount of liquid through the discharge port. Depending on the Controller Module mode, the piston will either stop after completing a dispense and wait until requested to dispense again or will automatically rotate to the intake port, retract to fill the chamber and then rotate back to the discharge port.

The end of the piston is never drawn back beyond the intake and discharge ports in normal operation. The piston flat allows only one port to communicate with the interior of the pump cylinder at any time. The effect of this is positive mechanical valving, eliminating the need for check valves under normal operations.

The pump, which cannot be driven by liquid pressure, essentially acts as a closed valve when the unit is not in operation.

7.2.1 Piston/Cylinder Set

The piston/cylinder set is constructed of high density alumina ceramic and/or magnesium partially stabilized zirconia ceramic. The ceramics are compatible with most acids and bases. The piston/cylinder set has a clearance between the piston and cylinder wall of approximately .00005" which minimizes fluid slip.

The ceramic piston operates within the ceramic cylinder with no lubrication other than the liquid being dispensed or metered. The natural crystalline structure of the ceramic displays zero porosity ensuring zero retention and carry over of one liquid to the next.

7.3. INSTALLATION

No installation of the Pump Module is required. Refer to section 7.5.3.1 for assembly and disassembly of the Pump Module to the Actuator Module.

7.4. OPTIONS

7.4.1 Ceramic Size and Materials

The Piston/Cylinder set is available in different sizes as shown in table 7.2.

The End Cap, End Cap Retainer, O-ring(s), Piston/Cylinder set and pump case are available in different materials.

7.4.2 Gland

The gland option provides for rinsing the rear portion of the piston with a liquid passing at a low flow rate through the annular gland. This precludes migration of the metered liquid beyond this groove, preventing it from reaching the rear of the pump. A gland also reduces the chance of the piston binding in the cylinder. The gland port accepts 1/4-28 male threaded fittings.

7.4.3 Port Size

The intake and discharge ports accept either 1/4-28 or 5/16-24 male threaded fittings.

7.5. MAINTENANCE (Figure 7.2)

CAUTION

Never connect or disconnect the cable from the Actuator Module connector while power is on. Damage to the equipment may result.

7.5.1. Preventative Maintenance

The ceramic components for the pump have been designed to last for millions of repetitions without wear. Preventative maintenance includes careful handling of the piston fabrication and cylinder housing when they have been removed from the pump assembly. Always take great care when removing the piston fabrication from the cylinder and replacing the piston fabrication into the cylinder. If the cleaning procedure includes removing the Pump Module and individually cleaning separate parts, always keep the Pump Module parts together, each piston fabrication with the cylinder housing to which it was originally mated. The number on the piston fabrication should match the number on the case. Never clean in such a way that the ceramics can vibrate against each other or chipping may result.

CAUTION

Ceramic piston/cylinder sets are particularly sensitive to neglect and may seize if allowed to dry out without adequate cleaning.

7.5.1.1 General Applications; Routine Cleaning Procedure.

1. Disconnect intake tubing from process liquid supply container.
2. Cycle pump in continuous mode until remaining process liquid has been purged from the Pump Module liquid path.
3. Connect the intake tubing to the cleaning liquid supply container.
4. Cycle pump in continuous mode at a high prime rate to flush the cleaning liquid through the entire liquid path.

NOTE

Routine flushing with a compatible liquid after shutdown may suffice for most applications.

7.5.2 O-Rings (Figure 7.2)

The inner O-ring (6B) serves to seal the head end of the pumping chamber. Over time, O-rings may lose elasticity and become deformed. Periodic Replacement of these O-rings is required. The replacement cycle is dependent on handling during assembly and disassembly in addition to the liquids being pumped.

Please contact technical support at IVEK Corporation with any questions or concerns you may have regarding the operation or maintenance of this module.

7.5.3 Assembly/Disassembly Procedures (Figure 7.2)

The Pump Module contains the following replaceable parts. Also contained in this section are the procedures for assembling and disassembling the Pump Module from the Actuator Module.

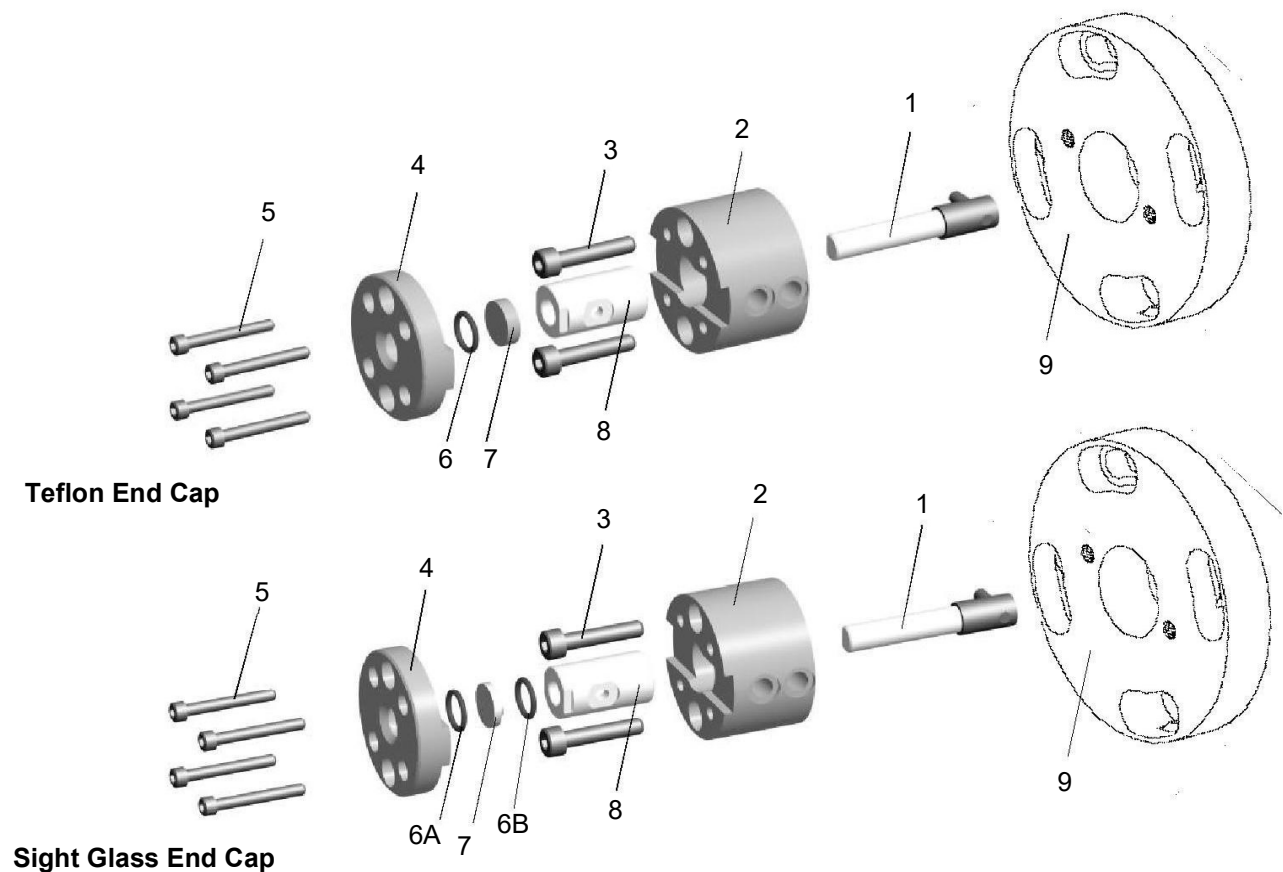

Figure 7.2 Micro SL Pump Module Components Assembly/Disassembly

- End Cap Retainer (4)
- Sight Glass End Cap (7) or optional Teflon End Cap/Seal (7)
- O-Rings (6, 6A and 6B)
- Case, Cylinder and Piston Fabrication (2,8 and 1)

WARNING

Make sure the power is OFF and all hazardous liquids have been flushed from the system prior to performing any disassembly or assembly procedures.

7.5.3.1 Pump Module (Figure 7.3)

IVEK systems are shipped with the Pump Module assembled onto the Actuator Module. The following procedures are only necessary if you received a new Pump Module or for disassembly/assembly of the Pump Module for maintenance, repair or change over.

Disassembly:

1. Loosen (do not remove) four #10-32 socket head cap screws (3) securing Pump Module (5) to Actuator Module (1).
2. Turn Pump Module (5) slightly counterclockwise and slowly remove.

NOTE

Piston (4) will stay attached to coupling (2).

3. Loosen two thumb screws (8) securing access cover (9) to Actuator Module (1).
4. Slide access cover (9) to one side.
5. Loosen (do not remove) two set screws (6) securing piston (4) in hub (2).
6. Remove piston (4).

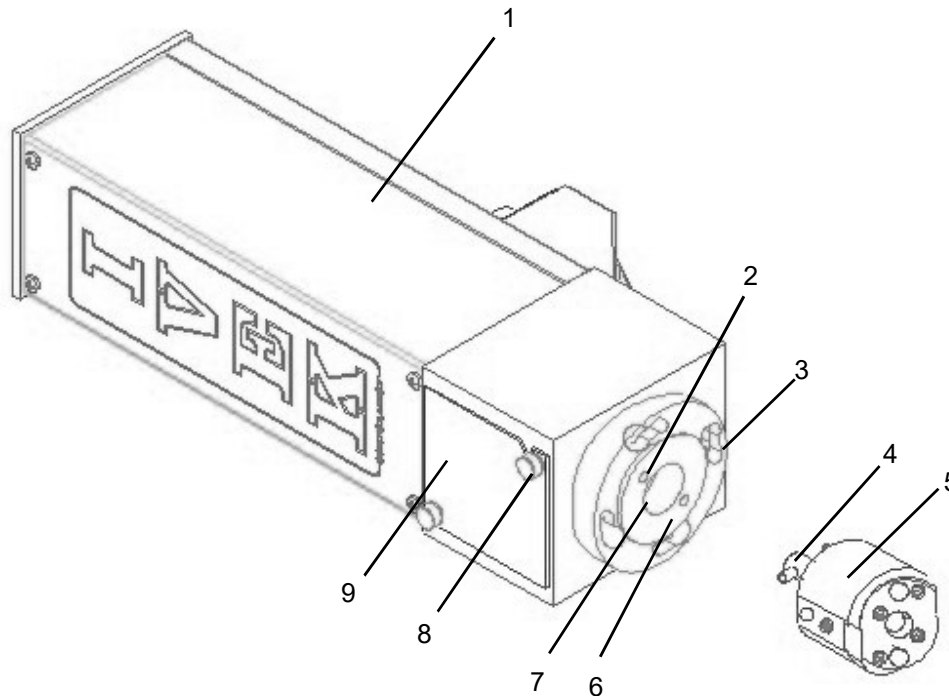

Figure 7.3 Micro SL Pump Module Assembly/Disassembly

Assembly:

1. Loosen two thumb screws (8) securing access cover (9) to Actuator Module (1).
2. Rotate access cover (9) to one side.
3. Remove piston (4) from Pump Module (5).
4. Slide the drive pin on piston (4) into coupling (2) slot. Make sure the drive pin is fully inserted and is resting against the bottom of the slot (7).
5. Secure piston (4) in coupling (2) with two set screws (6). Tighten firmly and evenly.
6. Rotate access cover (9) on Actuator Module (1) back into place and tighten two thumb screws (8).
7. Carefully align Pump Module (5) over piston (4) and gently slide it over piston (4) and four screws (3) until it abuts Actuator Module (1). Turn slightly clockwise and secure with four #10-32 socket head cap screws (3) torque to 5 in. lbs..

NOTE

Make sure the intake and discharge ports are properly orientated. (same as prior to removal).

7.5.3.2 End Cap Retainer, End Cap and O-rings (Figure 7.2 items 4, 7 and 6)

Disassembly

1. Remove four #4-40 socket head cap screws (5) securing end cap retainer (4) to case (2).

CAUTION

Be careful cylinder (8) does not fall out of case (2).

2. Remove end cap retainer (4).
3. Remove inner O-ring (6B), sight glass end cap (7) and outer O-ring (6A). OR if optional Teflon end cap/seal purchased.
4. Remove Teflon end cap/seal (7) and outer O-ring (6).

NOTE

*Clean and inspect seals (6 or 7) for damage prior to assembly. (Replace if necessary)
Assembly.*

5. Position outer O-ring (6A), sight glass end cap (7) and inner O-ring (6B) into the recessed diameter of end cap retainer OR if optional Teflon end cap/seal purchased.
6. Position outer O-ring (6) and Teflon end cap/seal (7) into the recessed diameter of end cap retainer (4).

NOTE

Install sight glass end cap with the reduced diameter facing towards the cylinder housing.

7. Position end cap retainer (4), with installed components into the recessed diameter of case (2).
8. Secure with four #4-40 socket head cap screws (5) and torque screws (5) to 5 in lbs.7.5.3.3 Case, Cylinder and Piston (Figure 7.2 Items 2, 8 and 1).

NOTE

The piston and cylinder are a matched set. If either the cylinder or piston needs replacing, both parts must be replaced.

Disassembly

1. Remove Pump Module from Actuator Module as described in section 7.5.3.1.
2. Remove two #8-32 socket head cap screws (3) securing case (2) to adapter ring (9) and remove adapter ring (9).
3. Remove four screws (5) securing end cap retainer (4) to case (2).
4. Remove end cap retainer (4).
5. Remove inner O-ring (6B), sight glass end cap (7) and outer O-ring (6A). OR if optional Teflon end cap/seal purchased.
6. Remove Teflon end cap/seal (7) and outer O-ring (6).
7. Remove cylinder (8) from case (2).

NOTE

Clean and inspect seals (6 or 7) prior to assembly. (Replace if necessary)

Assembly

1. Slide cylinder (8) into case (2) as shown in Figure 7.2.

CAUTION

Thread fittings into case (2) ports to prevent cylinder (8) from falling out of case (2).

2. Position outer O-ring (6A), sight glass end cap (7) and inner O-ring (6B) into the recessed diameter of end cap retainer (4). OR if optional Teflon end cap/seal purchased.
3. Position outer O-ring (6) and Teflon end cap/seal (7) into the recessed diameter of end cap retainer (4).

NOTE

Install sight glass end cap with the reduced diameter facing towards the cylinder housing.

4. Position case (2) with fittings installed onto end cap retainer (4), with installed components.
5. Secure with four #4-40 socket head cap screws (5) and torque screws (5) to 5 in lbs.
6. Assemble the Pump Module onto the Actuator Module as described in section 7.5.3.1.

7.6. PROBLEM GUIDE**7.6.1 Piston Seized In The Cylinder (Figure 7.3)**

If the piston seizes in the cylinder perform the following steps.

CAUTION

DO NOT TRY TO FORCE THE PISTON FREE! Damage to the piston/cylinder set or Actuator Module may occur.

1. Loosen two thumb screws (8) securing access cover (9) to Actuator Module (1).
2. Slide access cover (9) to one side.
3. Remove four bolts (3) securing Pump Module (5) to Actuator Module (1). Turn the Pump Module to gain access to the two screws (6) securing piston (4) in hub (2) and loosen (do not remove) two screws (6).
4. Carefully remove Pump Module (5) from Actuator Module (1).
5. Soak the whole assembly in a liquid compatible with the materials and process liquids.
6. After soaking, try removing the piston from the cylinder by applying a light torque to the piston using only your fingers (no tools).

If the aforementioned procedures fail, contact IVEK for technical help. It may be necessary to ship the Pump Module back to the factory. Provide a note describing, in detail, what conditions caused the seizure. It may also be necessary to return the Controller and Actuator Modules along with the Pump Module should realignment of the Pump Module drive components be required.

Table 7.1 contains a list of possible problems, causes and solutions for the Pump Module.

7.7 SPECIFICATIONS

Table 7.2 lists the volumetric output of the different size Pump Modules and different Controller Modules. Refer to the Title Page section of this manual for the Pump Module size provided with your system. Use the **Resolution mstep (µl)** column to determine the resolution for Microstep Controller Modules and the **Resolution (µl)** column for all other Controller Modules.

Table 7.2 Volumetric Output Of Micro Linear Pump Modules

| Size | Chamber Capacity (µL) | Resolution (µl) | Resolution mstep (µl) |
|------|--------------------------|--------------------|--------------------------|
| 4A | 20 | 0.010 | 0.002 |
| 3A | 50 | 0.025 | 0.005 |
| 2A | 100 | 0.050 | 0.010 |
| 1A | 200 | 0.100 | 0.020 |

7.8 MODEL NUMBER

The model number provides important information about the specifics of your Pump Module. Refer to this number when calling IVEK Technical support. The model number for your Pump Module is located in the Title Page section of this manual.

7.9 ILLUSTRATED PARTS BREAKDOWN

The illustrated parts breakdown (Figure 7.4) contains replacement parts for the Micro Linear Pump Module.

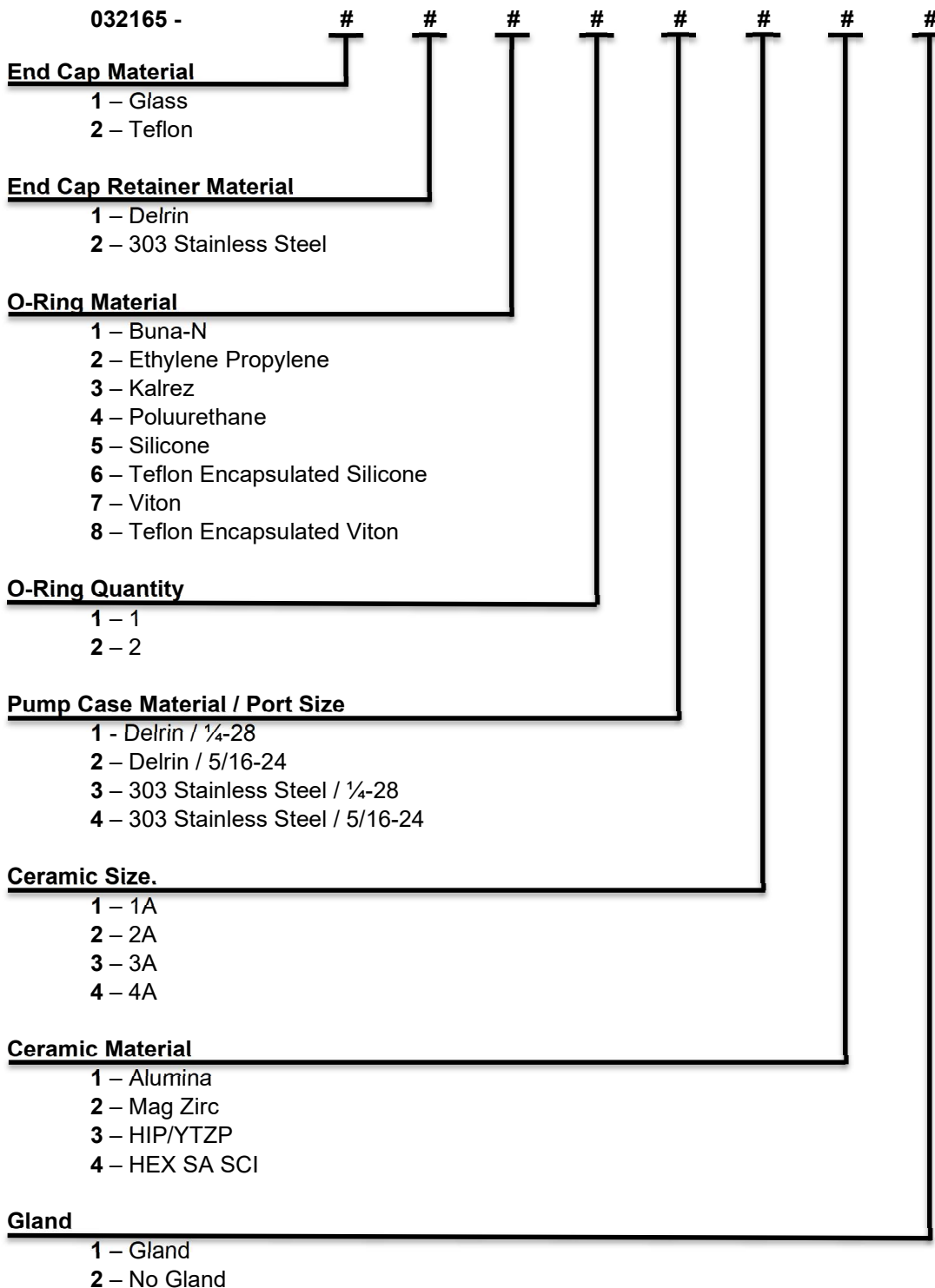

| Table 7.1 Common Operational Problems And Solutions | | |
|--|---|---|
| PROBLEM | PROBABLE CAUSE | POSSIBLE SOLUTION |
| Air evident in discharge line. | Loose/Damaged Fitting | Tighten/replace fittings. |
| | Loose/Damaged End Cap Seals | Clean, inspect and replace if necessary. |
| | Cavitation | Increase inlet tubing size or reduce Pump Module speed. |
| Piston seizing | Particulate materials entrapped between piston and cylinder. | Disassemble Pump Module and clean all wetted surfaces. |
| Fluid leaks | Improper seated or worn end cap retainer, sight glass, end cap or O-ring. | Disassemble Pump Module and clean all wetted surfaces, inspect components and replace if necessary. |
| | Loose/damaged fitting or tubing. | Inspect and replace if necessary. |
| Fluid not moving in tubing when priming, dispensing or metering. | Pump Module not properly oriented on Actuator Module. | Make certain that port holes in Pump Module line up with flat on piston. |
| | Loose Seals | Remove, inspect for scratches or damage, replace if necessary |
| Fluid syphoning when Pump Module is inactive. | High input/output pressure differential | Reduce input or output pressure |
| | Coupling position has moved causing port communication. | Remove end cap, actuate piston forward, measure the space between the end of the piston and the end of the cylinder. If greater than 0.020", call IVEK Technical Support. |
| | Tubing Adaptor fitting(s) are loose | Tighten fittings |

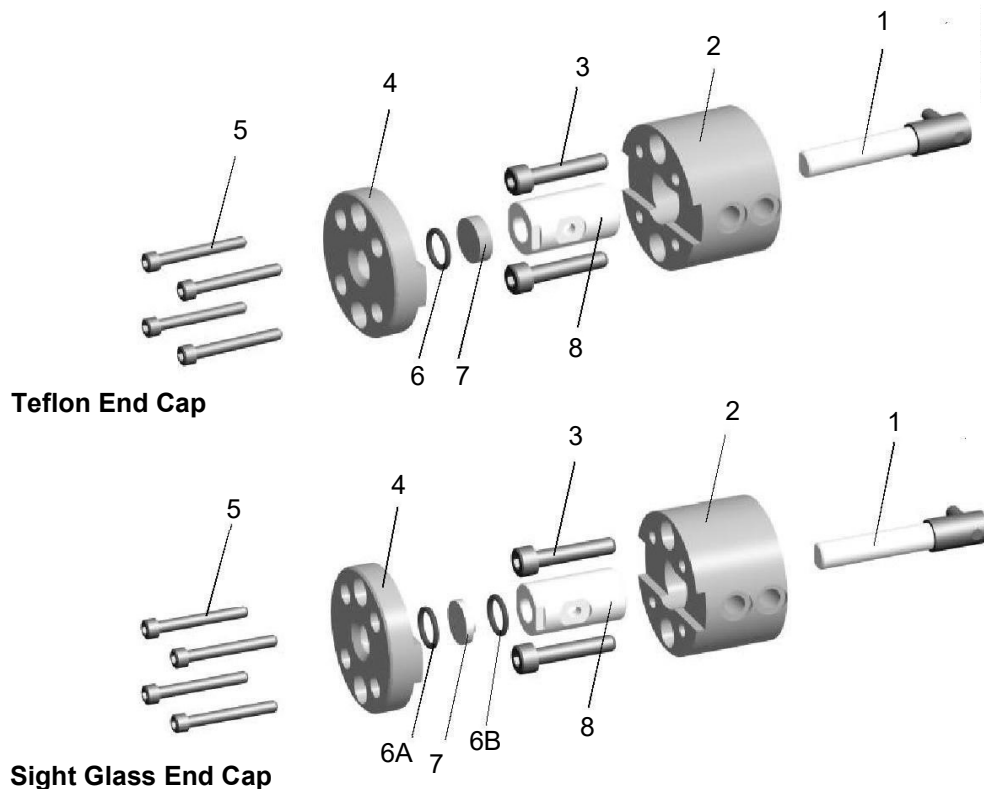

Figure 7.4 Micro SL Pump Module (Sheet 1 of 3)

| | | PART NUMBER | DESCRIPTION | UNITS PER ASSY |
|---|-------------|----------------|---|----------------|
| | | 032165 - ##### | Micro SL Pump Module | 1 |
| Model # Tab | Dwg Index # | Part # | Description | Qty |
| | 3 | 182009-0420 | Scr, Soc Hd Cap, 18-8; Metric | 2 |
| | 5 | 182011-C04088 | Scr, Soc Hd Cap, 18-8; Invh | 4 |
| 032165 - # ##### END CAP | | | | |
| 1 | 7 | 022044 | End Cap, Cyl, Sight Glass | 1 |
| 2 | 7 | 102104 | End Cap, Cyl, Teflon | 1 |
| 032165 - # # ##### END CAP RETAINER | | | | |
| 1 | 4 | 250012-001 | Retainer, End Cao, Micro SR; Delrin | 1 |
| 2 | 4 | 250012-002 | Retainer, End Cao, Micro SR; SST | 1 |
| 032165 - ## # ## O-RING MATERIAL | | | | |
| 11 | 6 | 142294-01101 | O-Ring; -011 Buna-N | 1 |
| 12 | 6 | 142294-01101 | O-Ring; -011 Buna-N | 2 |
| 21 | 6 | 142294-01102 | O-Ring; -011 Ethylene Propylene | 1 |
| 22 | 6 | 142294-01102 | O-Ring; -011 Ethylene Propylene | 2 |
| 31 | 6 | 142294-01103 | O-Ring; -011 Kalrez | 1 |
| 32 | 6 | 142294-01103 | O-Ring; -011 Kalrez | 2 |
| 41 | 6 | 142294-01104 | O-Ring; -011 Polyurethane | 1 |
| 42 | 6 | 142294-01104 | O-Ring; -011 Polyurethane | 2 |
| 51 | 6 | 142294-01105 | O-Ring; -011 Silicone | 1 |
| 52 | 6 | 142294-01105 | O-Ring; -011 Silicone | 2 |
| 61 | 6 | 142294-01106 | O-Ring; -011 Teflon Encapsulated Silicone | 1 |
| 62 | 6 | 142294-01106 | O-Ring; -011 Teflon Encapsulated Silicone | 2 |
| 71 | 6 | 142294-01107 | O-Ring; -011 Viton | 1 |
| 72 | 6 | 142294-01107 | O-Ring; -011 Viton | 2 |
| 81 | 6 | 142294-01108 | O-Ring; -011 Teflon Encapsulated Viton | 1 |
| 82 | 6 | 142294-01108 | O-Ring; -011 Teflon Encapsulated Viton | 2 |
| 032165 - ##### # ### PUMP CASE SIZE / MATERIAL | | | | |
| 1 | 2 | 250020-001 | Pump Case Fab; 1/4-28 / Delrin | 1 |
| 2 | 2 | 250020-002 | Pump Case Fab; 5/16-24 / Delrin | 1 |
| 3 | 2 | 250020-001 | Pump Case Fab; 1/4-28 / Stainless Steel | 1 |
| 4 | 2 | 250020-002 | Pump Case Fab; 5/16-24 / Stainless Steel | 1 |

| | | PART NUMBER | DESCRIPTION | UNITS PER ASSY |
|----------------|-------------|----------------|---|----------------|
| | | 032165 - ##### | Micro SL Pump Module | 1 |
| Model # Tab | Dwg Index # | Part # | Description | Qty |
| 032165 - ##### | | ### | CERAMIC SIZE/MATERIAL | |
| 111 | 1 | 022296-31131 | Piston/Cyl Set; 1A, Alumina w/ gland | 1 |
| 112 | 1 | 022296-31132 | Piston/Cyl Set; 1A, Alumina | 1 |
| 121 | 1 | 022296-21121 | Piston/Cyl Set; 1A, Mag Zirc w/ gland | 1 |
| 122 | 1 | 022296-21122 | Piston/Cyl Set; 1A, Mag Zirc | 1 |
| 141 | 1 | 022296-41141 | Piston/Cyl Set; 1A, Hex SA SIC w/ gland | 1 |
| 142 | 1 | 022296-41142 | Piston/Cyl Set; 1A, Hex SA SIC | 1 |
| 211 | 1 | 022296-32231 | Piston/Cyl Set; 2A, Alumina w/ gland | 1 |
| 212 | 1 | 022296-32232 | Piston/Cyl Set; 2A, Alumina | 1 |
| 221 | 1 | 022296-22221 | Piston/Cyl Set; 2A, Mag Zirc w/ gland | 1 |
| 222 | 1 | 022296-22222 | Piston/Cyl Set; 2A, Mag Zirc | 1 |
| 321 | 1 | 022296-23321 | Piston/Cyl Set; 3A, Mag Zirc w/ gland | 1 |
| 322 | 1 | 022296-23322 | Piston/Cyl Set; 3A, Mag Zirc | 1 |
| 331 | 1 | 022296-13321 | Piston/Cyl Set; 3A, Hip/YTZP w/ gland | 1 |
| 332 | 1 | 022296-13322 | Piston/Cyl Set; 3A, Hip/YTZP | 1 |
| 421 | 1 | 022296-14421 | Piston/Cyl Set; 4A, Hip/YTZP w/ gland | 1 |
| 422 | 1 | 022296-14422 | Piston/Cyl Set; 4A, Hip/YTZP | 1 |

| | | PART NUMBER | DESCRIPTION | UNITS PER ASSY |
|-------------------------|-------------|-----------------------------------|--|----------------|
| | | 072130-### | Heated Pump Case Assembly | 1 |
| Model # Tab | Dwg Index # | Part # | Description | Qty |
| | 3 | 182011-C08112 | Scr, Soc Hd Cap, 18-8; #8-32 x 1-1/8" | 2 |
| | 5 | 182011-C04038 | Scr, Soc Hd Cap, 18-8; #4-40 x 3/8" | 4 |
| | | 182005-C06019 | Scr, But Hd, Soc Cap, 18-8, Inch; #6-32 x 3/16" Long | 1 |
| | | 182005-C04038 | Scr, But Hd, Soc Cap, 18-8; #4-40 x 3/8" | 2 |
| END CAP | | | | |
| 1 | 7 | 022044 | End Cap, Cyl, Sight Glass | 1 |
| END CAP RETAINER | | | | |
| 1 | 4 | 102171-003 | Retainer, End Cap; AISI Type 303 STN STL | 1 |
| 072130- # # # | | O-RING MATERIAL | | |
| 1 | 6 | 142294-01101 | O-Ring, AS568; -011, Buna-N | 2 |
| 2 | 6 | 142294-01102 | O-Ring, AS568; -011, Ethylene Propylene | 2 |
| 3 | 6 | 142294-01103 | O-Ring, AS568; -011, Kalrez | 2 |
| 4 | 6 | 142294-01104 | O-Ring, AS568; -011, Polyethylene | 2 |
| 5 | 6 | 142294-01105 | O-Ring, AS568; -011, Silicone | 2 |
| 6 | 6 | 142294-01106 | O-Ring, AS568; -011, Teflon | 2 |
| 7 | 6 | 142294-01107 | O-Ring, AS568; -011, Teflon Encapsulated Silicone | 2 |
| 8 | 6 | 142294-01108 | O-Ring, AS568; -011, Viton | 2 |
| 9 | 6 | 142294-01109 | O-Ring, AS568; -011, Teflon Encapsulated Viton | 2 |
| 072130 - # # # | | HEATED PUMP CASE PORT SIZE | | |
| 1 | 2 | 072098-001 | Pump Case, Heated, Mirco; 1/4-28 Ports | 1 |
| 2 | 2 | 072098-002 | Pump Case, Heated, Mirco; 5/16-24 Ports | 1 |
| 022158 - ##### | | CERAMIC SIZE/MATERIAL | | |
| | 1 | 022158-213321 | Piston/Cylinder Set, 3A, Hip, w/ gland | 1 |
| | 1 | 022158-213322 | Piston/Cylinder Set, 3A, Hip/YTZP | 1 |
| | 1 | 022158-213332 | Piston/Cylinder Set, 3A, Hip-YTZP/Alumina | 1 |
| | 1 | 022158-214422 | Piston/Cylinder Set, 4A, Hip | 1 |
| | 1 | 022158-221122 | Piston/Cylinder Set, 1A, Zirc | 1 |
| | 1 | 022158-222222 | Piston/Cylinder Set, 2A, Mag Zirc | 1 |
| | 1 | 022158-224422 | Piston/Cylinder Set, 4A, Zirc | 1 |
| | 1 | 022158-231132 | Piston/Cylinder Set, 1A, Alumina | 1 |
| | 1 | 022158-232231 | Piston/Cylinder Set, 2A, Alumina w/ gland | 1 |
| | 1 | 022158-232232 | Piston/Cylinder Set, 2A, Alumina | 1 |
| | 1 | 022158-241142 | Piston/Cylinder Set, 1A, Hex SA SIC | 1 |