

----- Table Of Contents -----

Section	Description	Page #
3.	MULTIPLEXW/TOUCHSCREEN CONTROLLERMODULE	3-4
3.1	DESCRIPTION	3-4
3.1.1	Control Cabinet Front Panel (Figure 3.1)	3-4
3.1.1.1	Power Indicator (Figure 3.1 Item 1)	3-4
3.1.1.2	Touchscreen (Figure 3.1 Item 2).....	3-4
3.1.1.3	On/Off Switch (Figure 3.1 Item 3)	3-4
3.1.2	Control Cabinet Rear Panel (Figure 3.2).....	3-5
3.1.2.1	Power Entry Module (Figure 3.2 Item 1)	3-5
3.1.2.2	E-STOP Connector (Figure 3.2 Item 2)	3-5
3.1.2.3	MOTOR Connector (Figure 3.2 Item 3)	3-5
3.1.2.4	Fan (Figure 3.2 Item 4)	3-6
3.1.2.5	CONTROL A and CONTROL B Connectors (Figure 3.2 Item 5).....	3-6
3.1.2.6	CONTROLLER COMMUNICATION Connectors (Figure 3.2 Item 6)	3-6
3.1.2.7	LOGIC I/O Connector (Figure 3.2 Item 7).....	3-6
3.1.2.8	RS-232 INTERFACE Connector (Figure 3.2 Item 8)	3-6
3.2	OPERATION.....	3-6
3.2.1	Emergency Stop.....	3-6
3.2.1.1	Configuration.....	3-6
3.2.1.2	Connections	3-7
3.2.2	Control	3-8
3.2.3	Operating Modes.....	3-8
3.2.3.1	Prime.....	3-8
3.2.3.2	Dispense and Dispense MCV	3-8
3.2.3.3	Meter	3-8
3.2.3.4	Agitate	3-9
3.2.4	Other Operating Sequences	3-9
3.2.4.1	Reference.....	3-9
3.2.4.2	Drawback	3-9
3.2.4.3	Load	3-9
3.2.5	Touchscreen.....	3-9
3.2.5.1	Introduction	3-10
3.2.5.2	Permission Levels	3-10
3.2.5.3	Getting Started	3-11
3.2.5.4	Main Screen (Figure 3.5)	3-12
3.2.5.5	Setup Screen (Figure 3.6).....	3-12
3.2.5.6	Pump Screen (Figure 3.7).....	3-13
3.2.5.7	System Screen (Figure 3.8)	3-13
3.2.5.8	Logic In (Figure 3.9)	3-14
3.2.5.9	Logic Out Screen (Figure 3.10).....	3-14
3.2.5.10	Hardware Screen (Figure 3.11)	3-15
3.2.5.11	RS232 Interface Screen (Figure 3.12).....	3-15
3.2.5.12	Communication Configuration Screen (Figure 3.13)	3-16
3.2.5.13	Advanced Hardware Screen (Figure 3.14)	3-16
3.3	PARAMTER DESCRIPTIONS.....	3-17
3.3.1	Product ID [P001]	3-17
3.3.2	ADI Major Version [P002].....	3-17
3.3.3	ADI Minor Version [P003].....	3-17
3.3.4	Firmware Version [P004].....	3-17
3.3.5	Part Number [P006].....	3-17
3.3.6	Serial Number [P007]	3-17
3.3.7	Commands [P010].....	3-18
3.3.8	Status Flags [P012].....	3-18
3.3.9	Status Flags Extended [P013].....	3-19
3.3.10	State [P014])	3-20
3.3.11	Fault Code [P015]	3-20
3.3.12	Actuator Number [P020].....	3-21
3.3.13	Pump Chamber Volume [P024]	3-21
3.3.14	Pump Volume Resolution [P025]	3-21
3.3.15	Pump Rate Resoution [P026].....	3-21
3.3.16	Running Torque [P031]	3-21
3.3.17	Valve Dwell [P042]	3-22
3.3.18	Reference Rate [P043].....	3-22

3.3.19	Pumps Enabled [P044].....	3-22
3.3.20	Pumps Installed [P045]	3-22
3.3.21	Mode [P050]	3-23
3.3.22	Direction [P051].....	3-23
3.3.23	Dispense Volume [P052].....	3-23
3.3.24	Dispense Rate [P053]	3-23
3.3.25	Drawback Volume [P055].....	3-24
3.3.26	Drawback Rate [P056]	3-24
3.3.27	Drawback Dwell [P057].....	3-24
3.3.28	Load Mode [P058]	3-24
3.3.29	Pre-op Dwell [P065]	3-24
3.3.30	Post-op Dwell [P066].....	3-24
3.3.31	Agitate Volume [P082].....	3-24
3.3.32	Prime/Load Rate [P083].....	3-24
3.3.33	Agitate Dwell [P085].....	3-25
3.3.34	Agitate Isolation Volume [P086]	3-25
3.3.35	Prime Duration [P087]	3-25
3.3.36	Total Volume [P090].....	3-25
3.3.37	Volume Position [P092].....	3-25
3.3.38	Volume Remaining [P093].....	3-25
3.3.39	Total Cycles [P095]	3-25
3.3.40	HMI Lock Configuration [P127]	3-25
3.3.41	Erase Parameters [P138].....	3-25
3.3.42	Logic In 1 Configuration [P160].....	3-25
3.3.43	Logic In 2 Configuration [P161].....	3-25
3.3.44	Logic In 3 Configuration [P162].....	3-25
3.3.45	Logic In 4 Configuration [P163].....	3-25
3.3.46	Logic In 5 Configuration [P164].....	3-25
3.3.47	Logic In 1 Invert [P172]	3-26
3.3.48	Logic In 2 Invert [P173]	3-26
3.3.49	Logic In 3 Invert [P174]	3-26
3.3.50	Logic In 4 Invert [P175]	3-26
3.3.51	Logic In 5 Invert [P176]	3-26
3.3.52	Logic In 1 [P184]	3-26
3.3.53	Logic In 2 [P185]	3-26
3.3.54	Logic In 3 [P186]	3-26
3.3.55	Logic In 4 [P187]	3-26
3.3.56	Logic In 5 [P188]	3-26
3.3.57	Start I/O Test [P197].....	3-26
3.3.58	Logic Out 1 Configuration [P200]	3-26
3.3.59	Logic Out 2 Configuration [P201]	3-26
3.3.60	Logic Out 3 Configuration [P202]	3-26
3.3.61	Logic Out 4 Configuration [P203]	3-26
3.3.62	Logic Out 5 Configuration [P204]	3-26
3.3.63	Logic Out 6 Configuration [P205]	3-26
3.3.64	Logic Out 1 Invert [P212].....	3-27
3.3.65	Logic Out 2 Invert [P213].....	3-27
3.3.66	Logic Out 3 Invert [P214].....	3-27
3.3.67	Logic Out 4 Invert [P215].....	3-27
3.3.68	Logic Out 5 Invert [P216].....	3-27
3.3.69	Logic Out 6 Invert [P217].....	3-27
3.3.70	Logic Out 1 [P224].....	3-27
3.3.71	Logic Out 2 [P225].....	3-27
3.3.72	Logic Out 3 [P226].....	3-27
3.3.73	Logic Out 4 [P227].....	3-27
3.3.74	Logic Out 5 [P228].....	3-27
3.3.75	Logic Out 6 [P229].....	3-27
3.4	REAR PANEL CONNECTIONS	3-27
3.4.1	LOGIC I/O Interface	3-27
3.4.1.1	Signal Functions.....	3-27
3.4.1.2	Connections	3-28
3.4.2	RS-232 Interfaces	3-28
3.4.2.1	Command Structure	3-29
3.4.2.2	Response String.....	3-30
3.4.2.3	Commands.....	3-31
3.4.2.4	Warnings	3-37

3.4.2.5	Faults	3-38
3.4.2.6	Typical Command Sequence.....	3-38
3.5	INSTALLATION	3-40
3.6	OPTIONS.....	3-40
3.7	MAINTENANCE	3-40
3.8	PROBLEM GUIDE.....	3-40
3.9	SPECIFICATIONS.....	3-40
3.10	MODEL NUMBER	3-41
3.11	ILLUSTRATED PARTS BREAKDOWN	3-41

----- List of Figures -----

Number	Description	Page #
3.1	Multiplex Version 3.0 Controller Module Front Panel	3.4
3.2	Multiplex Version 3.0 Controller Module Rear Panel	3.5
3.3	Emergency Stop Wiring Configuration	3.7
3.4	Screen navigation	3.10
3.5	Main Screen.....	3-12
3.6	Setup Screen	3-12
3.7	Pump Screen	3-13
3.8	System Screen	3-13
3.9	Logic In Screen.....	3-14
3.10	Logic Out Screen	3-14
3.11	Hardware Screen.....	3-15
3.12	RS-232 Screen	3-15
3.13	Communication Screen	3-16
3.14	Advanced Screen	3-16

----- List of Tables -----

Number	Description	Page #
3.1	Logic I/O Interface	3-28
3.2	RS232 Communication	3-29
3.3	Commands	3-31
3.4	Problem Guide.....	3-42

3. MULTIPLEXW/TOUCHSCREEN CONTROLLERMODULE

3.1 DESCRIPTION

The Multiplex Version 3.0 Controller Module, hereafter referred to as the Controller Module, contains all the control, monitoring, and interface components for the dispensing operations. The control cabinet measures 448.9mm (17.7") wide, 434.2mm (17.1") deep, 184.5mm (7.3") high (feet included) and weighs approximately 11.4kg (25 pounds). The operator indicators, controls, and interface connections are located on the front and rear panels.

3.1.1 Control Cabinet Front Panel (Figure 3.1)

The front panel of the Controller Module control cabinet contains the system indicators and the main power switch. The following indicators and switch are located on the front panel.

1. Power Indicator
2. Touchscreen
3. On/Off Switch

3.1.1.1 Power Indicator (Figure 3.1 Item 1)

This power indicator illuminates green when the power is ON and is off when the power is OFF.

3.1.1.2 Touchscreen (Figure 3.1 Item 2)

The touchscreen is the operator interface for controlling the system. Multiple screens are provided for setting and monitoring system parameters. With a touch of the screen, parameters can be viewed and changed to meet specific requirements.

3.1.1.3 On/Off Switch (Figure 3.1 Item 3)

This 2-position rocker switch turns controller main power "ON" (1) or "OFF" (0).

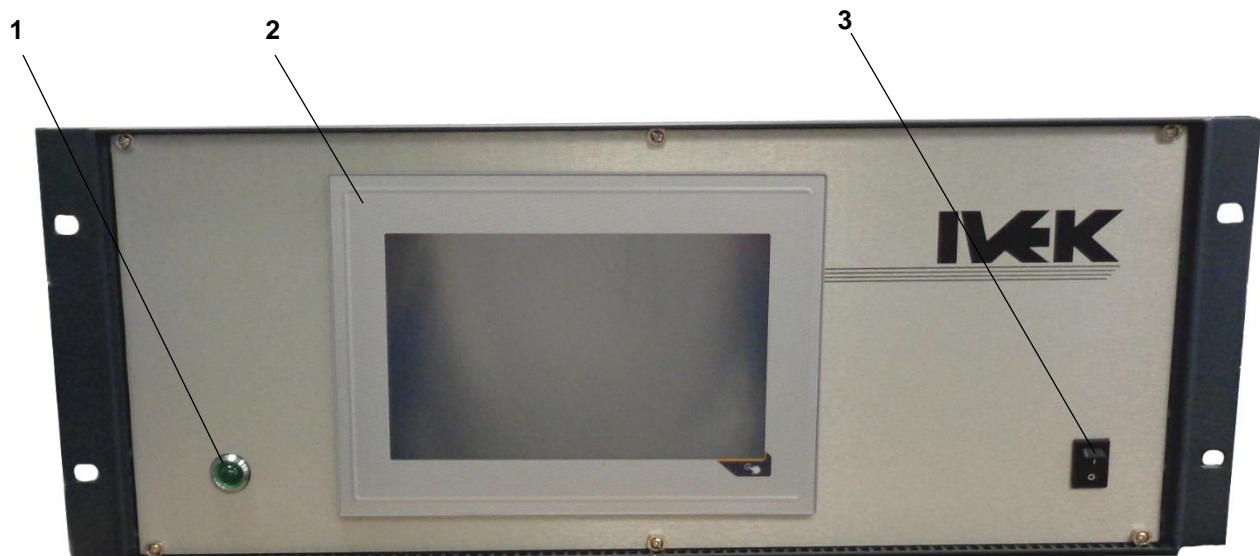

Figure 3.1 Multiplex Version 3.0 Controller Module Front Panel

3.1.2 Control Cabinet Rear Panel (Figure 3.2)

The control cabinet rear panel contains the following:

1. Power Entry Module
2. E-STOP Connector
3. MOTOR Connector
4. Cooling Fan
5. CONTROL A and Control B Connectors
6. CONTROLLER COMMUNICATION Connectors
7. LOGIC I/O Connector
8. RS-232 INTERFACE Connector

The power entry module provides an entry point for power coming into the Controller Module and the main line fuse(s). The control connectors (Motor, Control A and Control B) interface to the motor, valves, and sensors on the Actuator Module. The emergency stop (E-Stop) enables or disables power to the motor. The Logic I/O connector provides connections to the customer's PLC using discrete I/O. The controller communication connector provides a connection to the customer's PLC using an Ethernet based fieldbus. The RS232 interface connector provides an alternate connection to the customer's PLC using RS232.

3.1.2.1 Power Entry Module (Figure 3.2 Item 1)

The power entry module contains a receptacle for a standard IEC power cord and main fuse holder.

The design of the power entry module requires that the line cord be disconnected before the line fuse is removed. To replace the fuse, disconnect the line cord at the power entry module and open the fuse cover.

3.1.2.2 E-STOP Connector (Figure 3.2 Item 2)

This provides the connection to the emergency stop switch (or switches). The emergency stop switch must be connected for the controller to operate.

An E-Stop Connector Kit (Part Number 540108) is supplied with the unit.

3.1.2.3 MOTOR Connector (Figure 3.2 Item 3)

The controller has a 19-pin connector on the rear panel used to connect to the Multiplex motor. The motor provides linear motion for the pump assemblies. This connector provides both power and feedback to and from the motor.

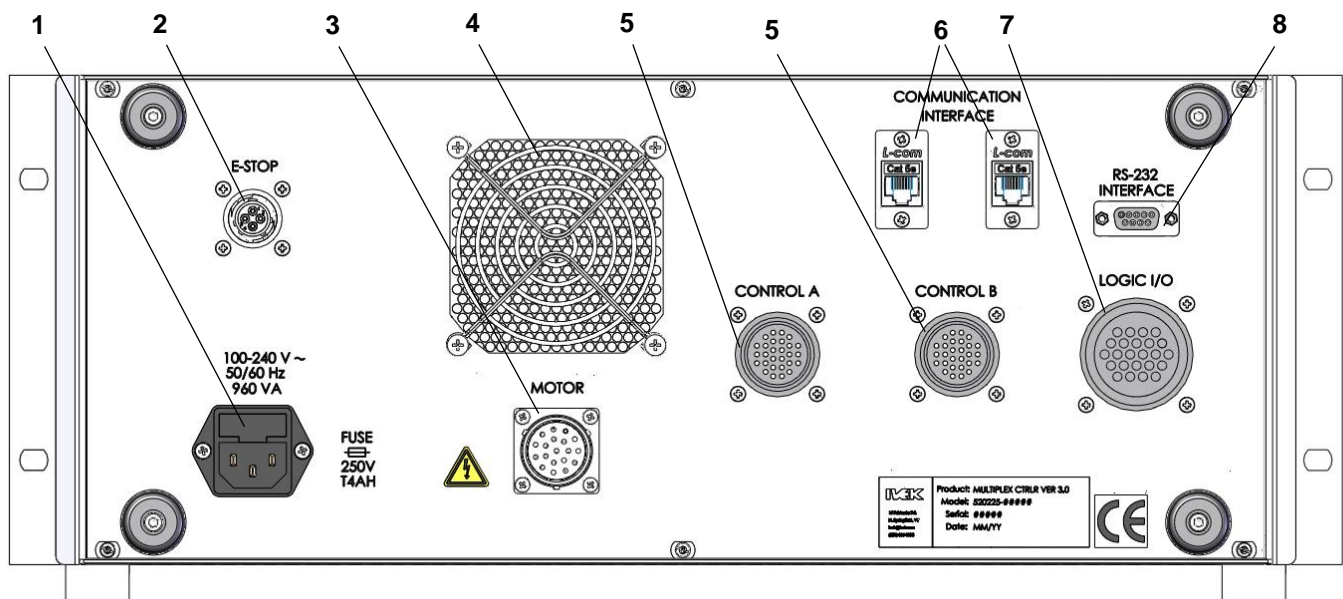

Figure 3.2 Multiplex Version 3.0 Controller Module Rear Panel

CAUTION

Never connect or disconnect the cable from this connector while power is on. Damage to the equipment may result.

3.1.2.4 Fan (Figure 3.2 Item 4)

The fan helps reduce the internal temperature of the Controller Module. Ensure the area around the fan is clear of obstructions.

3.1.2.5 CONTROL A and CONTROL B Connectors (Figure 3.2 Item 5)

The controller has two 28-pin connectors on the rear panel used to control and sense the Multiplex pump assembly valves. The valve actuators are air driven. This connector provides solenoid control and sensor feedback for each valve. The Control A connector is used for pump modules 1 through 8 and the linear position sensors. The Control B Connector is used for the remaining Pump Modules and linear position sensor. For systems controlling actuators with eight or less Pump Modules, Control B is not required.

3.1.2.6 CONTROLLER COMMUNICATION Connectors (Figure 3.2 Item 6)

The RJ45 connectors provide fieldbus communication between the PLC and Controller Module. The two connectors are switched so either connector may be used. For star topology, use either connector. For either a linear or ring topology, use both connectors.

3.1.2.7 LOGIC I/O Connector (Figure 3.2 Item 7)

The Logic I/O connector provides connections to various external components such as PLCs. (See section 3.4.1)

A PLC Connector Kit (Part Number 540112) is supplied with the unit. The pins in the connector kit accept 20-gauge to 24-gauge wire.

3.1.2.8 RS-232 INTERFACE Connector (Figure 3.2 Item 8)

The RS-232 interface provides control of all available functions and provides point-to-point communication. The hardware is configured as Data Communications Equipment (DCE) standard. Refer to section 3.4.2 for additional information.

3.2 OPERATION

The Controller Module provides the controls for producing liquid flow via a positive displacement pumping mechanism. The systems utilize solid-state electronics, state-of-the-art motor drives, and precision machined ceramic pump heads. These components combine to provide exceptional accuracy and precision, high reliability, and low maintenance.

IVEK units have custom designed motors and pumps sized to the specific dispensing application to provide the proper torque and speed. The Emergency Stop must be configured to operate the system.

3.2.1 Emergency Stop

The Emergency Stop provides a means of applying and removing air and motor power for the Multiplex Actuator(s). When energized, the relay interface provides power to the controllers' motor drive electronics and energizes an air dump valve located in the actuator. For convenience, connections to an internal 24 VDC fused power source are provided in the connector for energizing the relay.

3.2.1.1 Configuration

Wire the Emergency Stop switch (customer provided) in series with relay coil(s) and suitable external 24 Volt power source using the Connector Kit (IVEK provided part # 540108). See the sections below for the switch and power source requirements and pinout of the connector. External circuit protection (a series fuse) is required to be provided by the customer if an external 24 VDC power source is used to energize the relay coil. Only one 24 VDC power source should be used. Under no circumstance should more than one supply be wired to another supply in parallel. Refer to Figure 3.3.

3.2.1.2 Connections

PIN	SIGNAL
1	E-STOP IN +
2	E-STOP IN -
3	+24 Vdc
4	24V Return

Single Channel Configuration

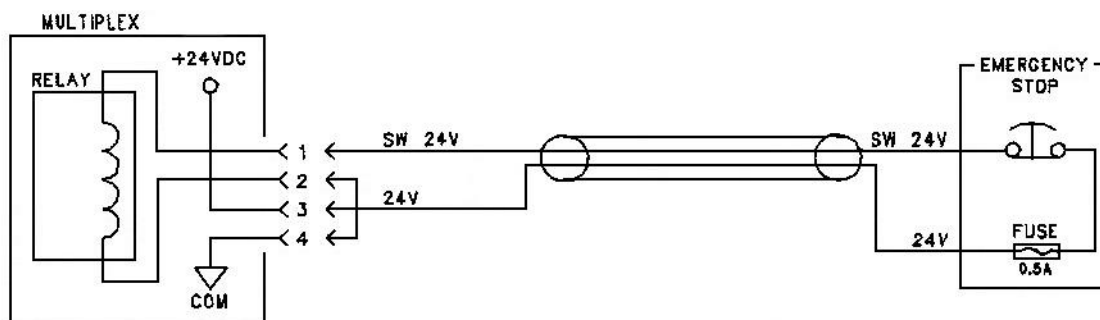

Multiple Channel Configuration

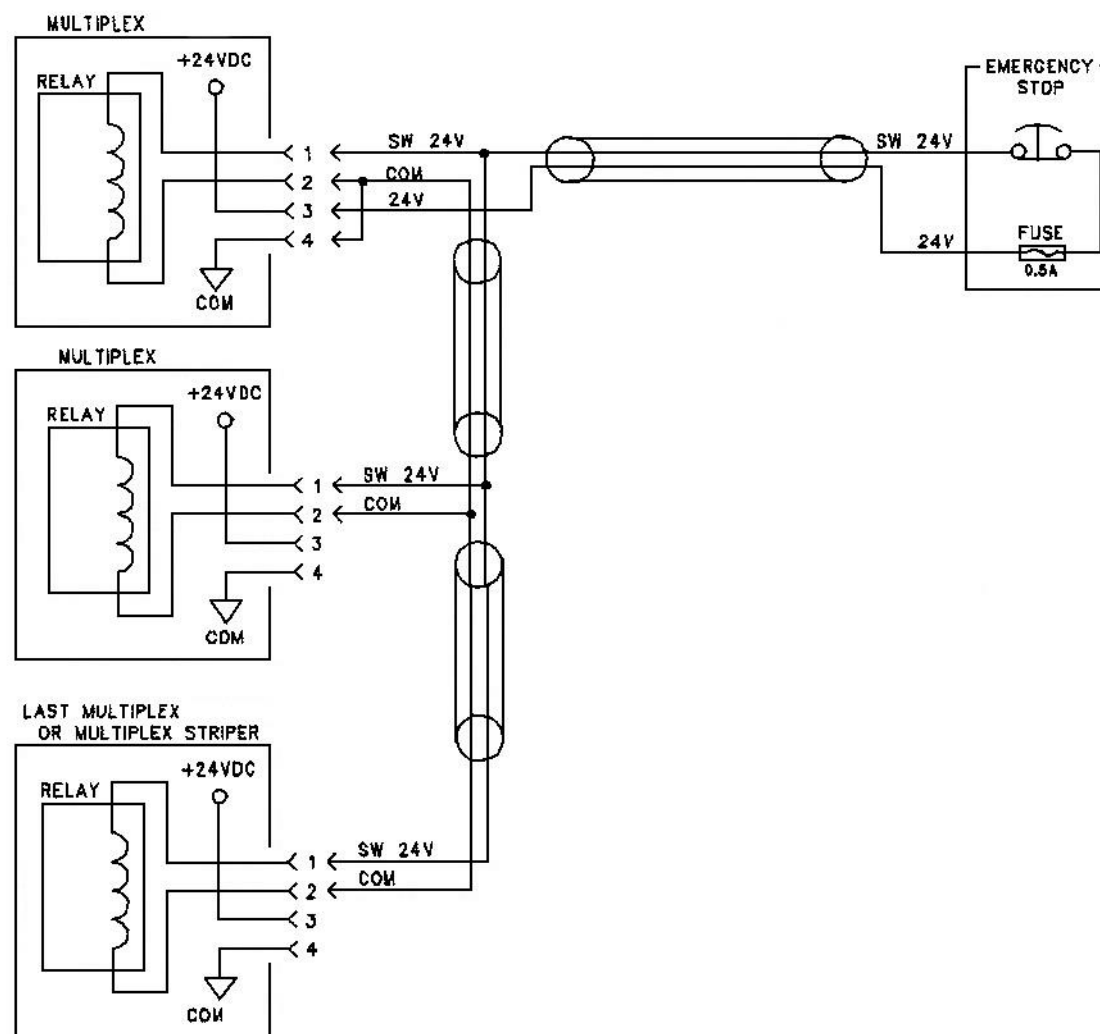

Figure 3.3 Emergency Stop Wiring Configuration

3.2.2 Control

All operational parameters on the Controller Module are programmed using the touchscreen. Total electronic control allows for effortless, exacting calibration and full accountability of cumulative volumes dispensed. Software contained in the Controller Module allows configuration and operation on a system-wide or individual Actuator Module basis.

3.2.3 Operating Modes

There are five main operating modes which provide the Controller Module with its vast functional flexibility. For all the operating modes the volume commands use increments and rate commands are in increments per second.

3.2.3.1 Prime

Prime mode produces a continuous cycle to pump fluid in one direction. The current setting for the liquid direction determines the direction of the fluid flow. The operating mode and liquid direction setting can be viewed in the Setup screen (Figure 3.6). Pumping is started using the "START" button in the Main screen (Figure 3.5). The pumping will continue until the "STOP" Button is pressed or until the maximum time set with the "PRIME DURATION" button in the

Setup screen (Figure 3.6) is reached. The time-out ensures a communications problem will not result in the pumps operating forever.

Prime is used to fill the system with fluid in preparation for actual operation, empty the system of fluid, and flush the system for cleaning.

The flow rate for priming is set in the Setup screen (Figure 3.6). Volume pumped during prime operation does not accumulate on the totalizer viewed in the System screen (Figure 3.8).

3.2.3.2 Dispense and Dispense MCV

Dispense and Dispense MCV (minimum chamber volume) modes are used to deliver a specific volume of fluid at a specific rate. Dispense MCV will only fill the chamber with the amount of liquid to be dispensed. Dispense fills the entire chamber. The current setting for the liquid direction determines the direction of the fluid flow. The operating mode and liquid direction setting can be viewed in the Setup screen (Figure 3.6). Pumping is started using the "START" button in the Main screen (Figures 3.5). The dispense cycle will continue until the volume, set using the Setup screen (Figure 3.6) has been delivered, unless the "STOP" button is pressed.

The volume and the rate are set in the Setup screen (Figure 3.6). A Load cycle is required anytime the mode is changed to or from Dispense MCV Mode.

NOTE

When recovering from a fault while operating in Dispense MCV mode, after a Reference is complete, initiate a Load Cycle.

3.2.3.3 Meter

Meter mode is used to deliver fluid at a specific rate for a specific time determined by hardwired input signals or through the touchscreen. The operating mode and liquid direction setting can be viewed in the Setup screen (Figure 3.6). The most accurate and repeatable method to control metering operation uses the hardwired PLC inputs. Pumping starts when the hardwired signal is present and will stop when the hardwired signal stops. Pumping can also be operated with the "START" and "STOP" buttons in the Main screen (Figures 3.5).

In meter mode, the pump will stop as soon as possible without regard to the reference position of the pump. If switching from Meter to Dispense mode, a "LOAD" should be performed before the first dispense to place the pump in the reference position.

The metering rate is set in the Setup screen (Figure 3.6).

Volume pumped during meter operation accumulates on the totalizer which is viewed in the System screen (Figure 3.8).

3.2.3.4 Agitate

Agitate is a unique mode used to prevent fluid from setting in the pumps or pump lines during extended idle times. Agitate mode is a reverse action followed by a sequence of reverse and forward pumping to keep the liquid in the lines and Pump Modules moving. The operating mode setting can be viewed in the Setup screen (Figure 3.6). Pumping is started using the "START" button in the Main screen (Figures 3.5). The agitate cycle will continue until the "STOP" button is pressed.

The Agitate Volume specifies the strokes the pump will operate in reverse then forward. The Isolation Volume specifies the number of full strokes operated in reverse. The Agitate Volume specifies the strokes the pump will operate in reverse then forward. The Agitate Dwell specifies the wait time between each reverse and forward cycle. All three of these settings are viewable in the Setup screen (Figure 3.6)

3.2.4 Other Operating Sequences

3.2.4.1 Reference

A reference is always required on Power Up.

Under certain conditions the controller may require a reference cycle when a fault occurs because it does not sense the rotary position of the piston. When the "REFERENCE" button on the main screen (Figure 3.5) is pressed, the piston will find the rotary home and stop at this position.

A reference cycle may be required after any fault before a command resulting in motion of the pump is accepted.

3.2.4.2 Drawback

Drawback is a controlled reverse flow at the end of a dispense to improve volume repeatability when 'stringy' fluids are being dispensed. If no drawback is required, the drawback volume is simply set to 0.

The Drawback settings are done in the Setup screen (Figure 3.6). When drawback is used, the "VOLUME" button specifies the net fluid displaced, the actual forward motion is the sum of the specified dispense volume and the drawback volume. The flow rate during drawback as well as the dwell (time between the forward and reverse portions of the cycle) are specified with the "DRAWBACK RATE" and "DRAWBACK DWELL" buttons, respectively.

3.2.4.3 Load

The load cycle is used to refill the pumping chamber with fluid after dispensing or metering. The piston will valve to the intake port (inlet), fill the pump chamber with fluid, and valve back to the discharge port (outlet). The system can be configured to start a load cycle on either of three conditions: empty, every or manual. The Load setting is done in the Setup screen (Figure 3.6).

When the system is configured for 'load empty', a load cycle will start when the pump is idle and the remaining volume in the pump chamber is less than the volume required for the next dispense.

When the system is configured for 'load every', a load cycle will start at the completion of every dispense or meter operation.

When the system is configured for 'load manual', a load cycle will only be initiated when the "LOAD ALL" button in the Volume And Rate screen is pressed.

3.2.5 Touchscreen

The touchscreen provides an operator interface to all operating parameters in the Controller Module. New values can be entered, and current values displayed for all the functions of the system. The touchscreen contains ten different operator interface screens with each providing information to the operator. Start and Stop buttons appear on two screens for starting and stopping the system.

3.2.5.1 Introduction

Buttons - A button initiates a command being sent to the Controller Module. The "Start" and "Stop" area in the Main screen (Figure 3.5) are examples of buttons.

Boxes - A box looks like a button but provides information only. Pressing a box will have no effect on the system. The "Total Volume" area in the System Screen (Figure 3.8) is an example of a box.

Screens - There are ten screens used to setup, operate, and exit the system as shown in Figure 3.4. Each screen contains information relating to operating the system. The system status is displayed on each screen and the ability to stop the current operation is available on each screen. The screens and a brief description are as follows:

Main Screen - The system can be operated from this screen.

Setup Screen –The system parameters are set on this screen.

Pump Screen - The actuator type is displayed. The torque multiplier, dwell and reference rate are displayed.

System Screen – Totalizer and system configuration is displayed on this screen.

Logic In Screen – The logic in settings are configured on this screen.

Logic Out Screen – The logic out settings are configured on this screen.

Hardware Screen – The hardware settings are configured on this screen.

RS-232 Interface Screen – The RS-232 settings are configured on this screen.

Communication Configuration Screen – The communications interface settings are configured on this screen.

Advanced Hardware Screen – Torque and temperature status are displayed, and piston increments are set on this screen.

3.2.5.2 Permission Levels

There are three levels of permission: Operator, Manual and Supervisor. Each level allows access to selected items on the touchscreen.

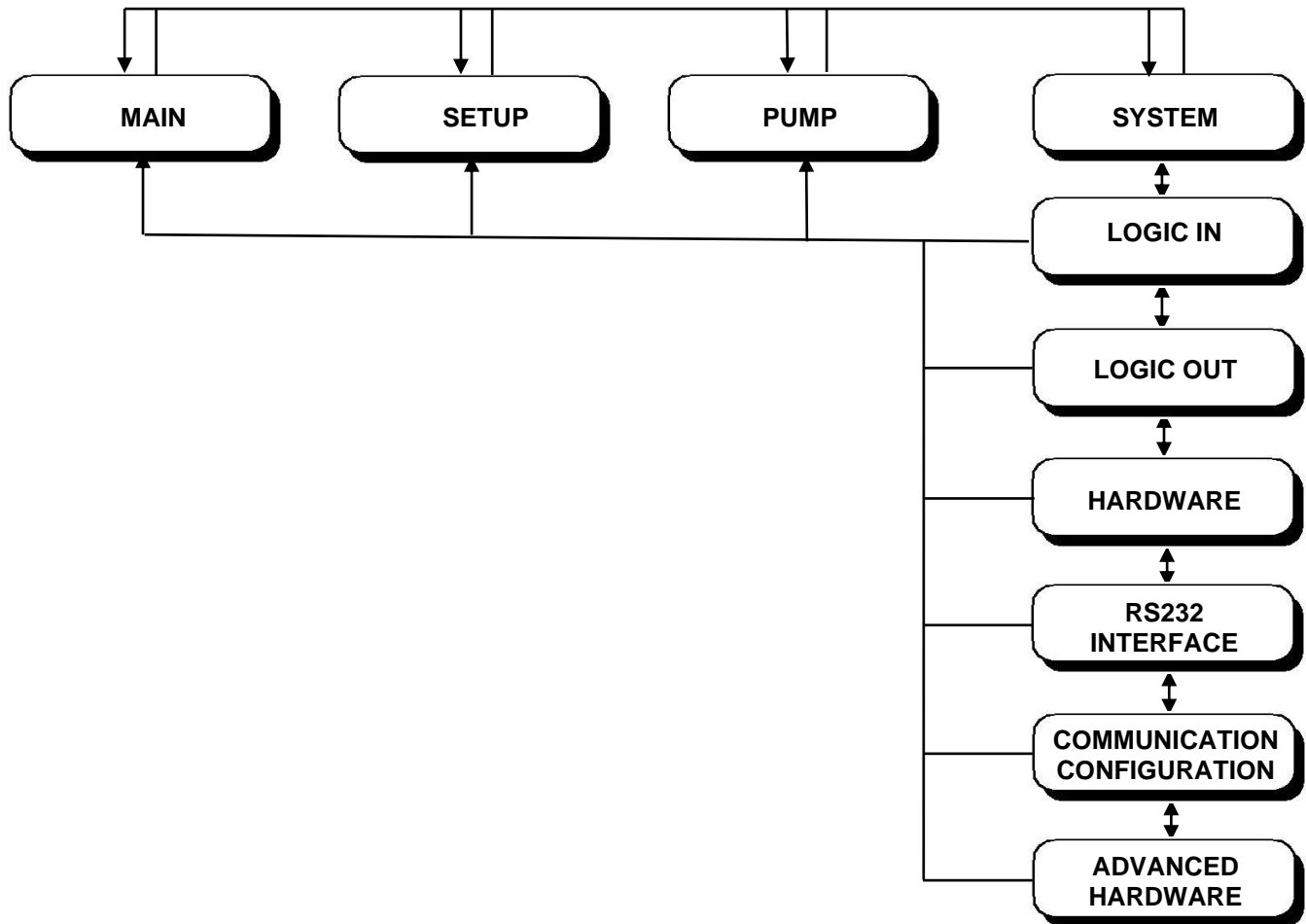

Figure 3.4 Screen Navigation

The permission level can be changed by using the parameter on the Hardware System Screen by entering the Permission and Password for the desired permission level.

The highest level is **Supervisor**. This level allows access to all items on all screens.

The **Manual** level does not allow changing system parameters other than the I/O Test parameters (Figure 3.6).

The **Operator** level does not allow changing system parameters.

3.2.5.3 Getting Started

The touchscreen will "Boot" when the power to the Controller Module is turned on. The "Boot" sequence will be visible on the touchscreen and takes approximately one minute.

The last values entered into the touchscreen before it was turned off will appear after the system has booted.

The first screen displayed will be the Main screen (Figure 3.5). This screen is displayed each time power is turned on. The "REFERENCE" button must be pressed before the system will perform pumping operations.

NOTE

If the "REFERENCE" button is not pressed, the system will not trigger, and no fault messages will be displayed.

3.2.5.4 Main Screen (Figure 3.5)

The Main screen is normally used to operate the system. The Setup, Pump and System screens are accessible from this screen. The current permission level determines which buttons are available.

The "START" button will start the system using the current parameters. The system will operate until the operation is completed or the "STOP" button is pressed. The "READY" box indicates the state of the READY output in the PLC Interface. If the system is not Ready, the icon will change color and display "BUSY". The Load button will prepare the system for dispensing.

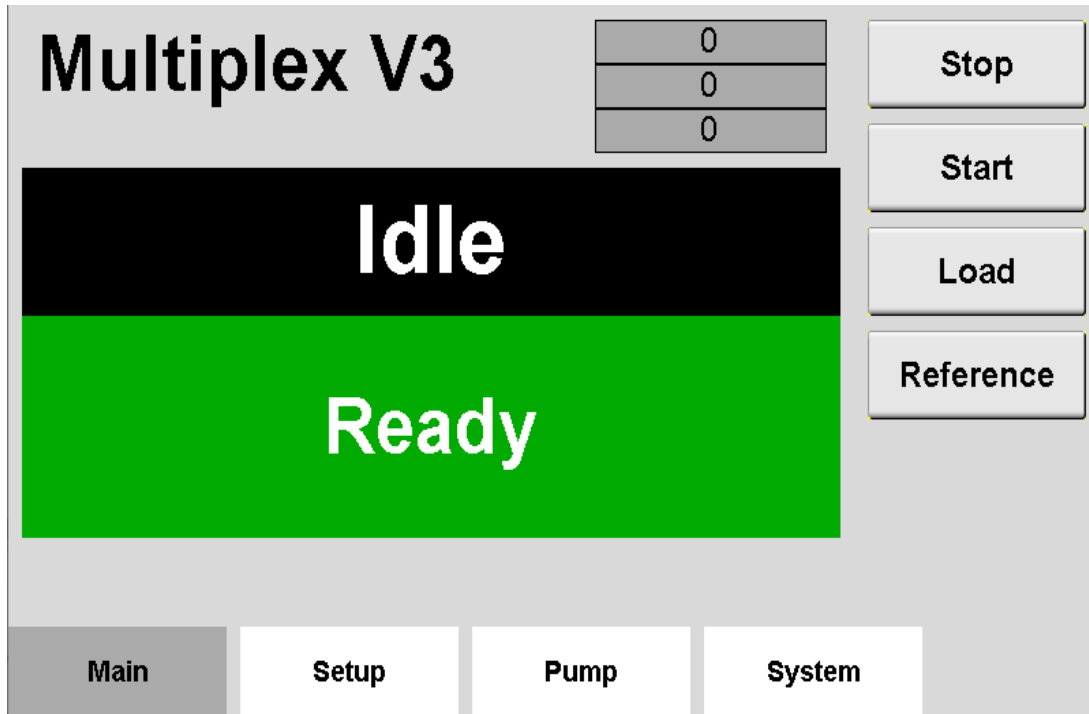

Figure 3.5 Main Screen

3.2.5.5 Setup Screen (Figure 3.6)

The Setup screen display the information on a variety of functions and allows changing the Mode, Direction and Load Mode for the system.

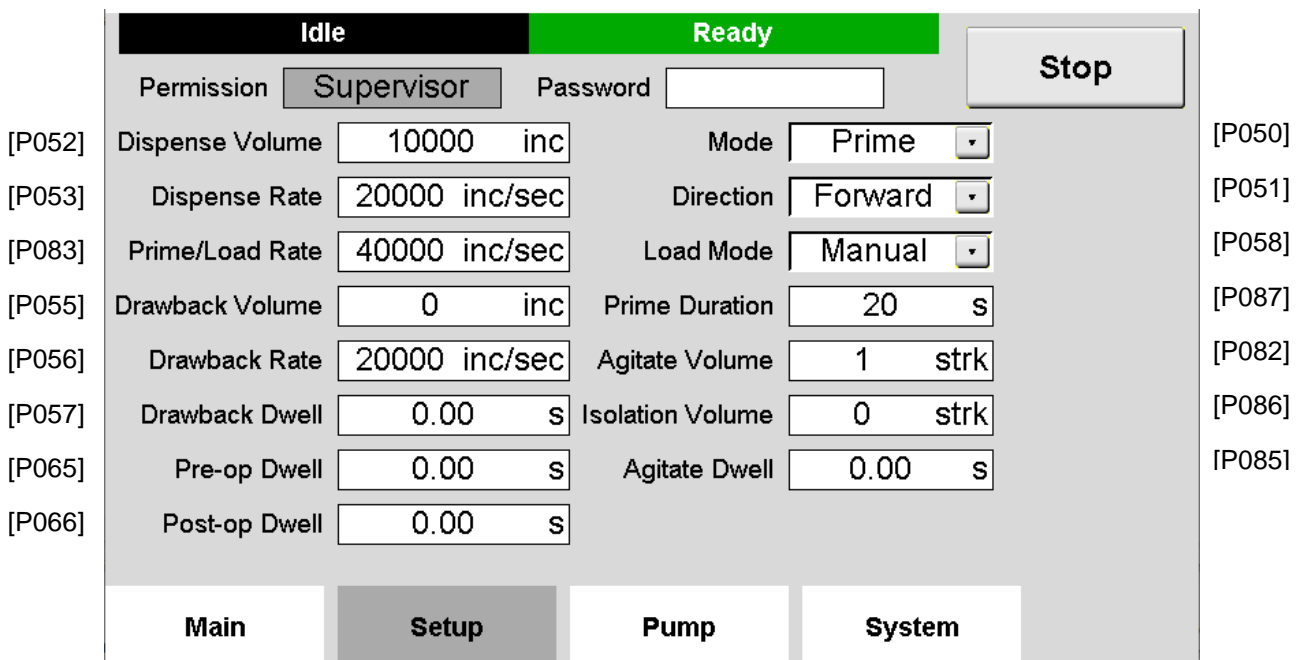

Figure 3.6 Setup Screen

3.2.5.6 Pump Screen (Figure 3.7)

The Pump screen displays the enabled pumps and where the Actuator type is selected.

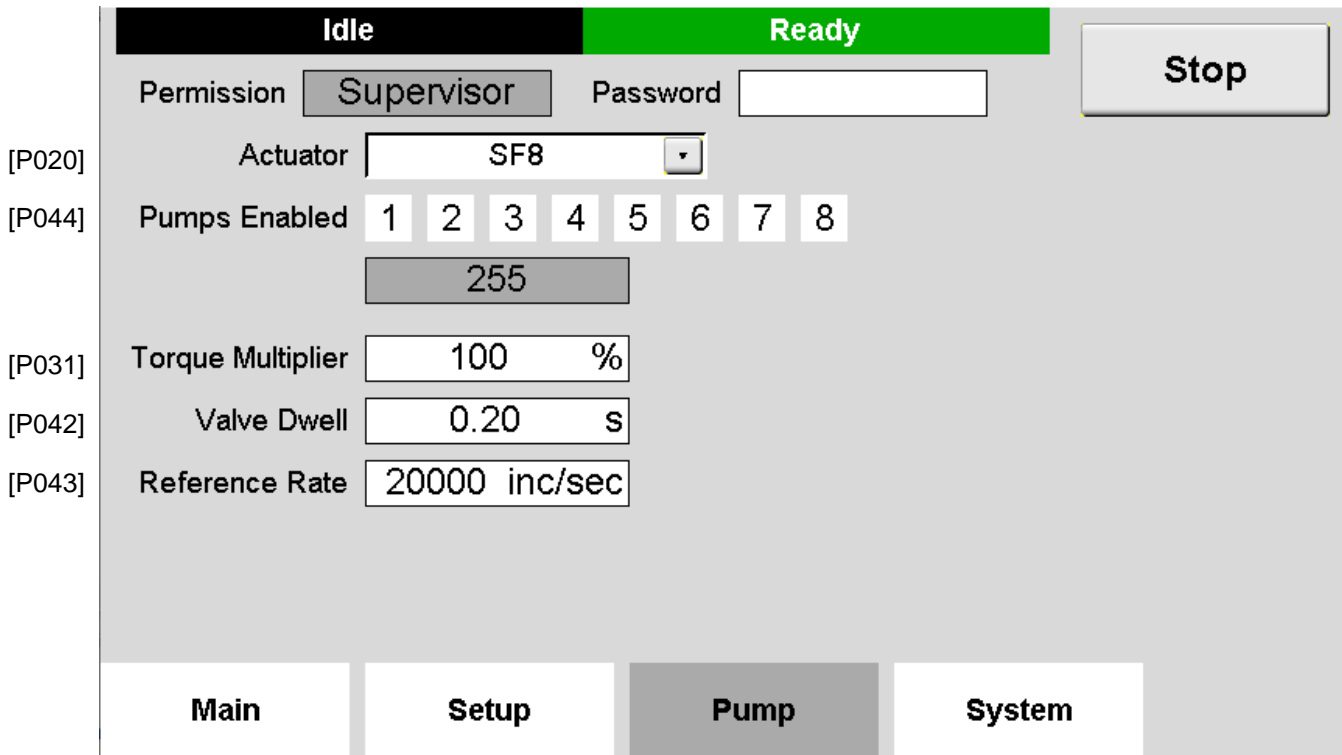

Figure 3.7 Pump Screen

3.2.5.7 System Screen (Figure 3.8)

The System screen information about the Controller Module. This information will be asked for when calling IVEK for information.

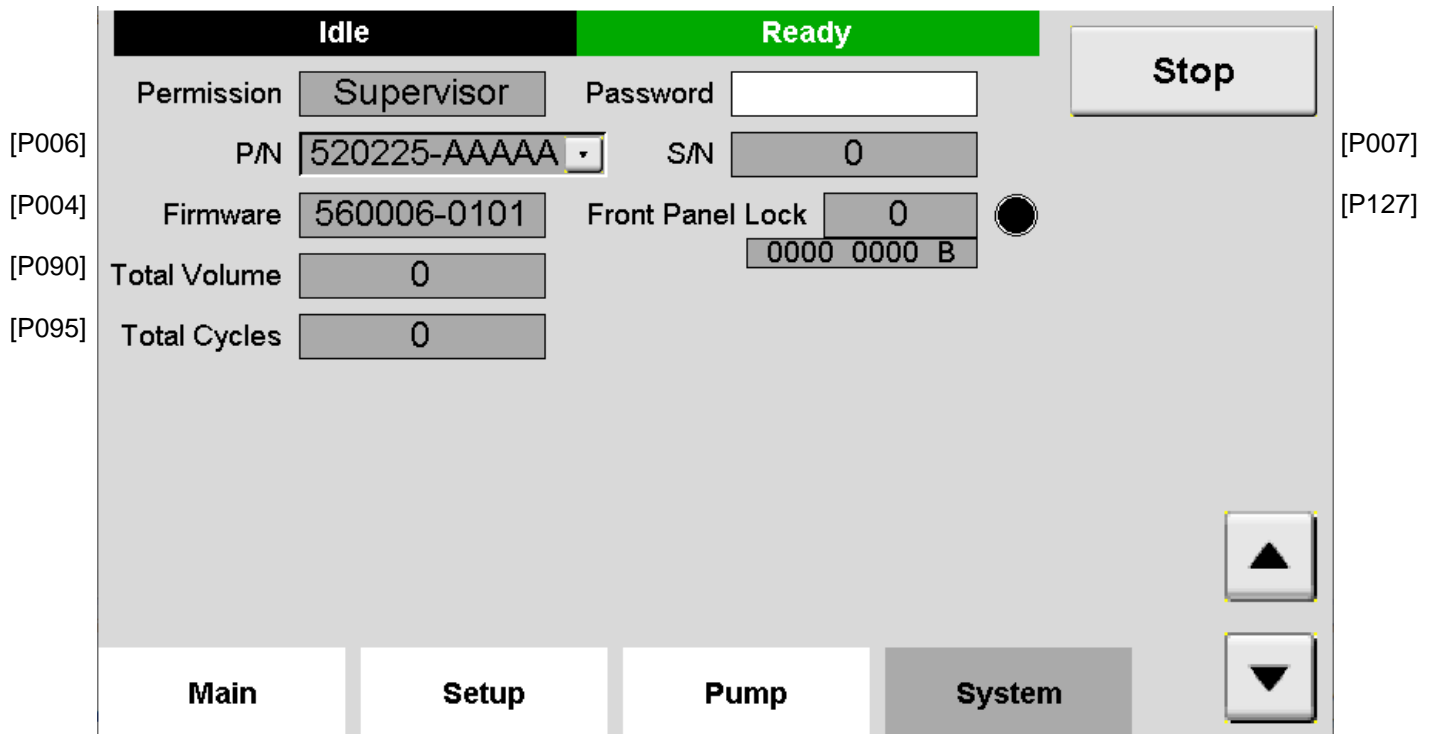

Figure 3.8 System Screen

3.2.5.8 Logic In (Figure 3.9)

The Logic In screen provides configuration of the five Logic In signals for initiating operations of the Controller.

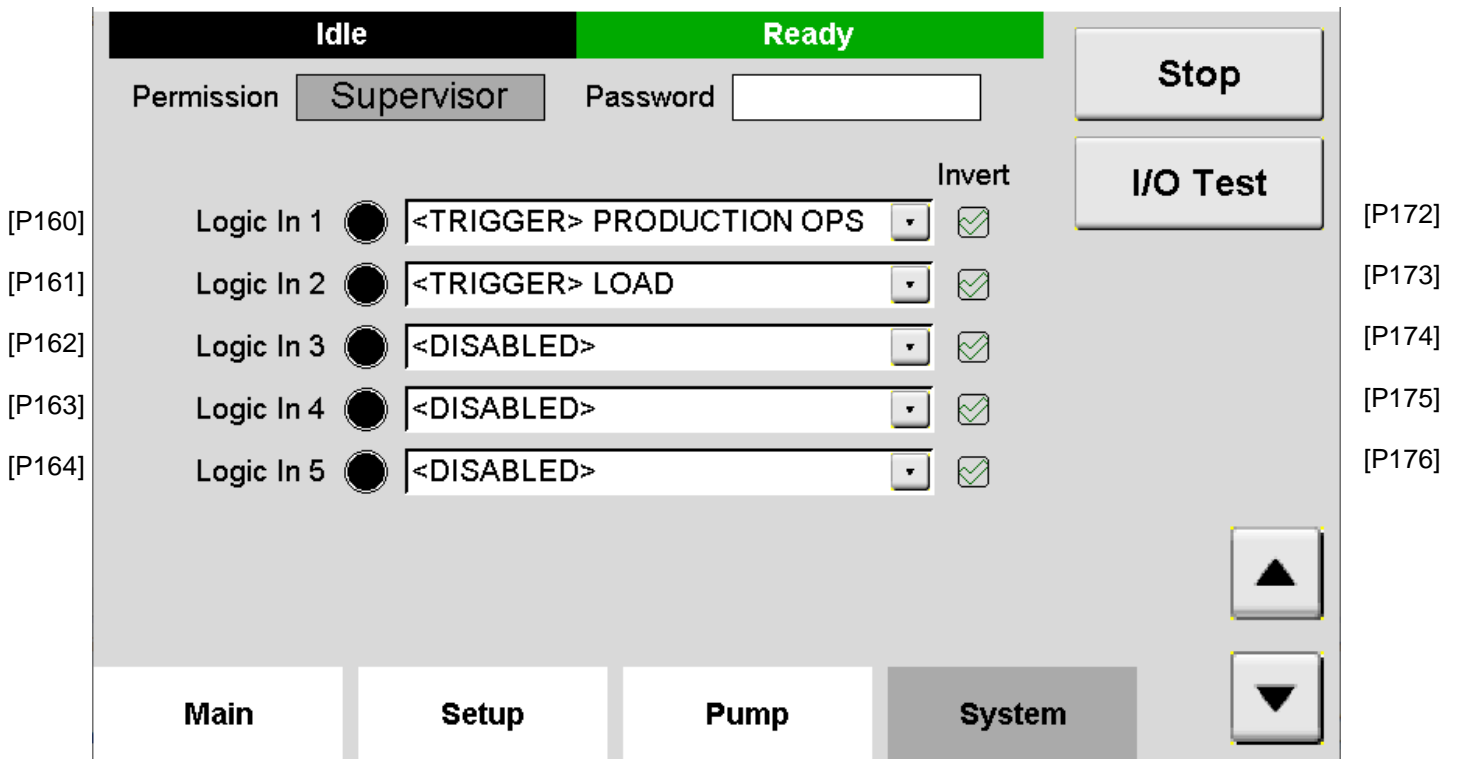

Figure 3.9 Logic In Screen

3.2.5.9 Logic Out Screen (Figure 3.10)

The Logic Out screen provides configuration of the six Logic Out signals for monitoring that status of the Controller.

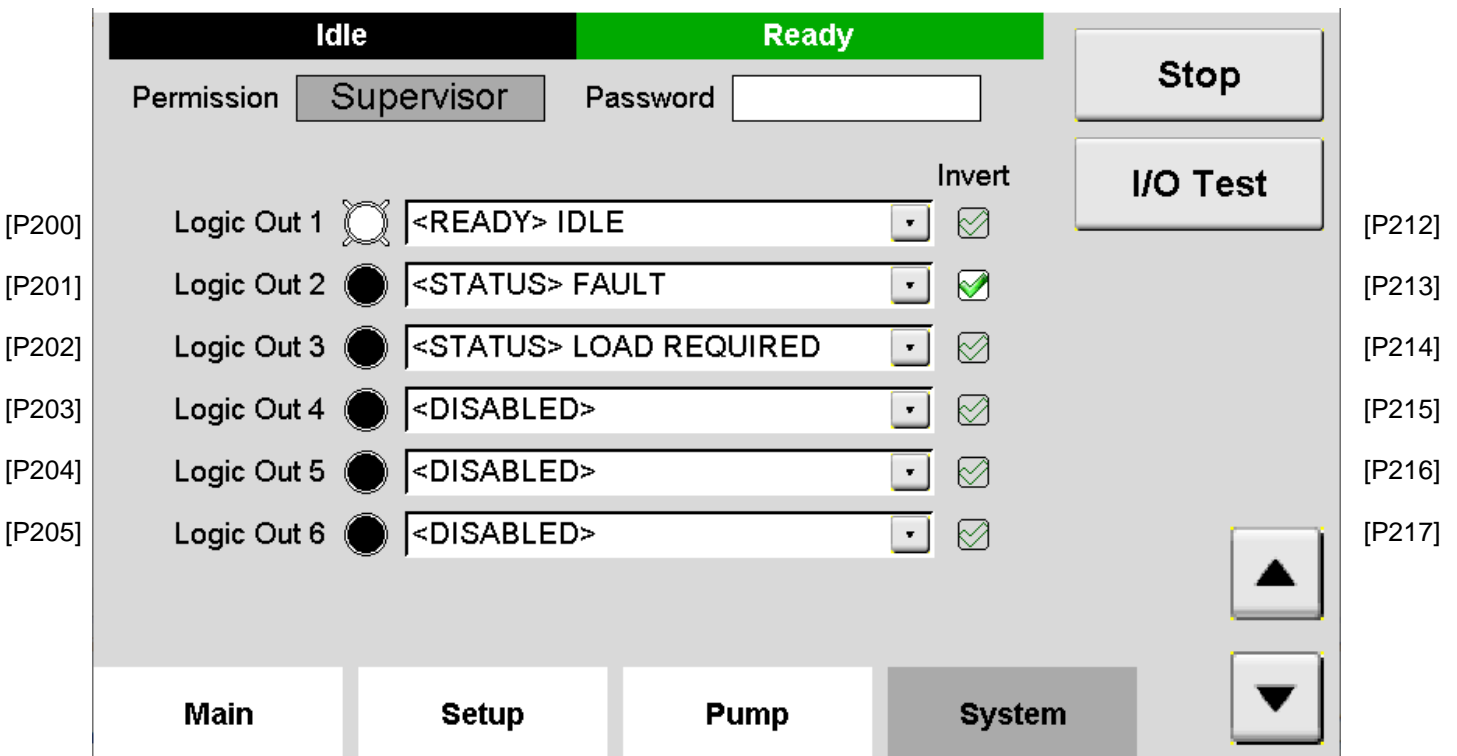

Figure 3.10 Logic Out Screen

3.2.5.10 Hardware Screen (Figure 3.11)

The Hardware Screen displays information pertaining the system’s hardware including valves and cables.

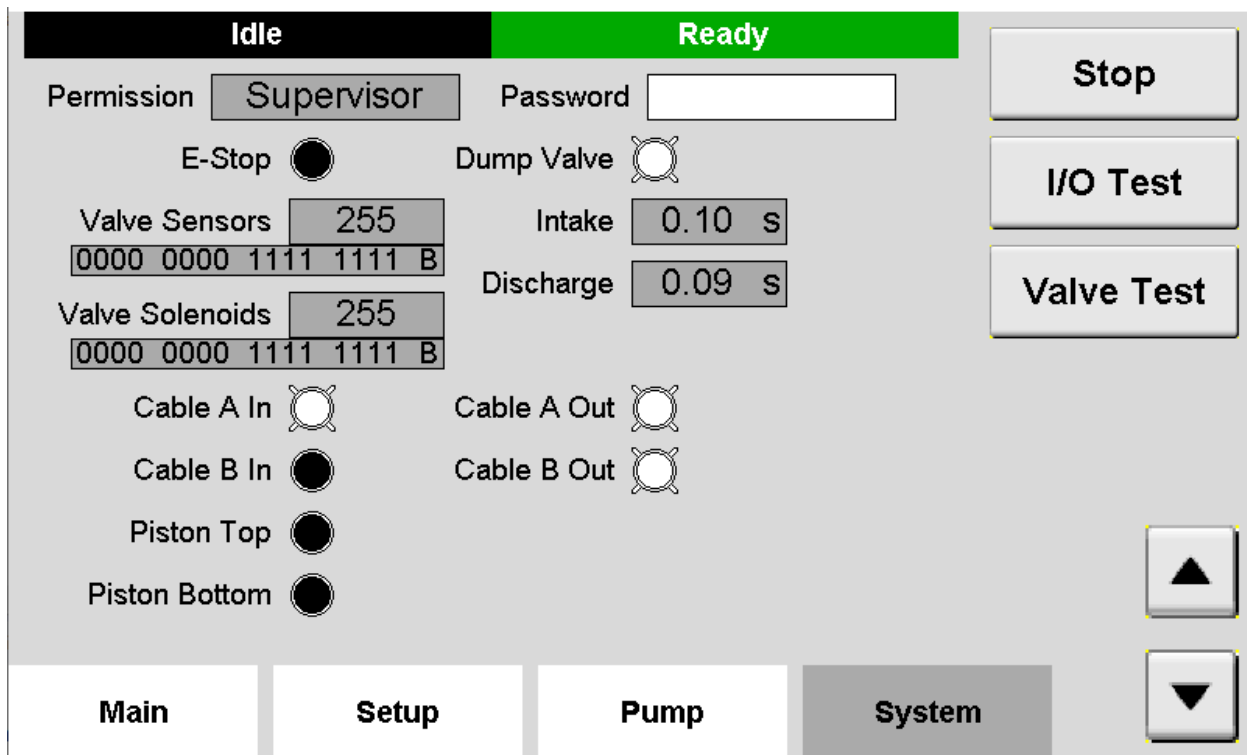

Figure 3.11 Hardware Screen

3.2.5.11 RS232 Interface Screen (Figure 3.12)

The RS232 Interface screen displays the information related to the RS232 interface.

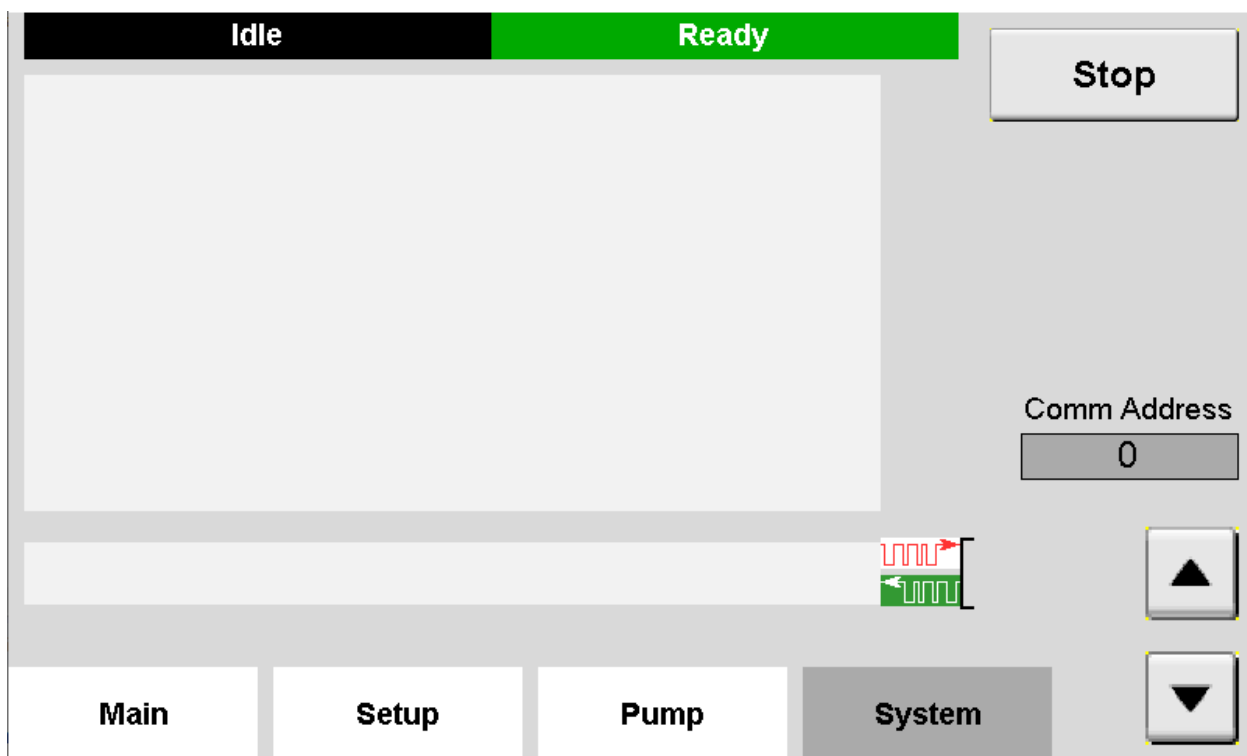

Figure 3.12 RS232 Interface Screen

3.2.5.12 Communication Configuration Screen (Figure 3.13)

The communication Configuration screen contains the IP Mode selection and displays the communication information.

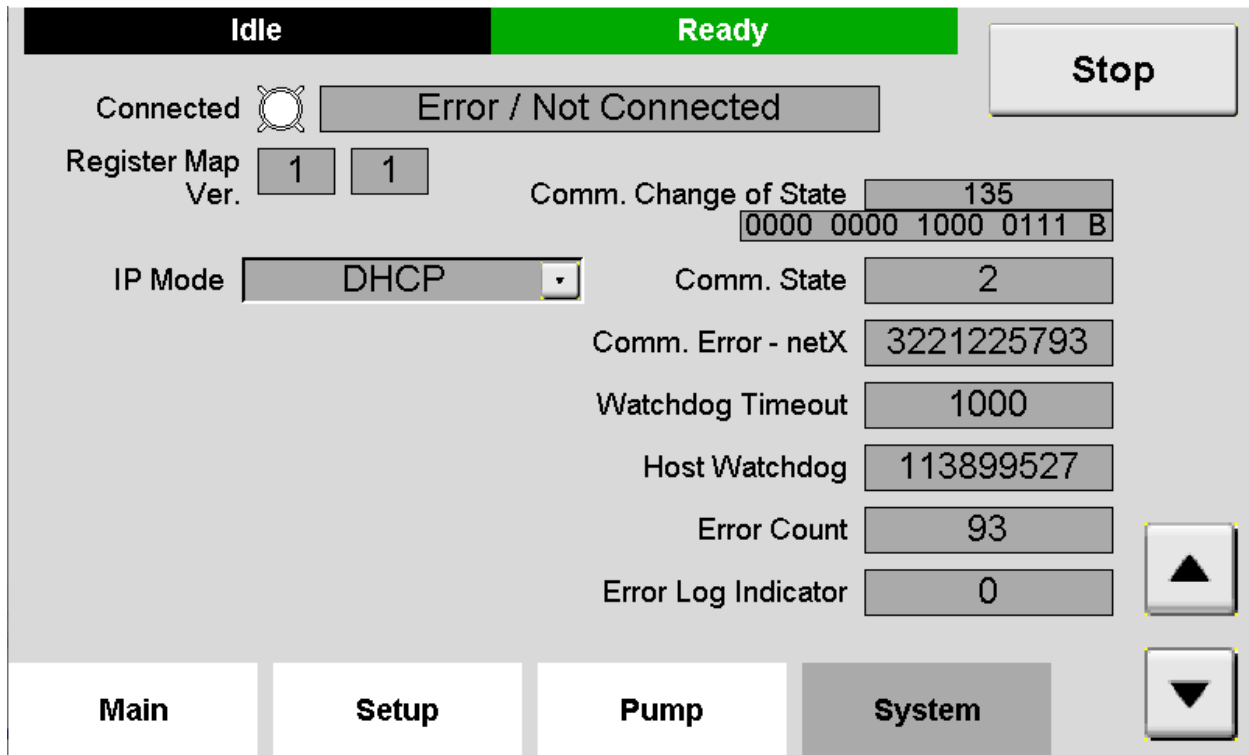

Figure 3.13 Communication Configuration Screen

3.2.5.13 Advanced Hardware Screen (Figure 3.14)

The Advanced Hardware screen displays internal temperature data, torque information and piston position information.

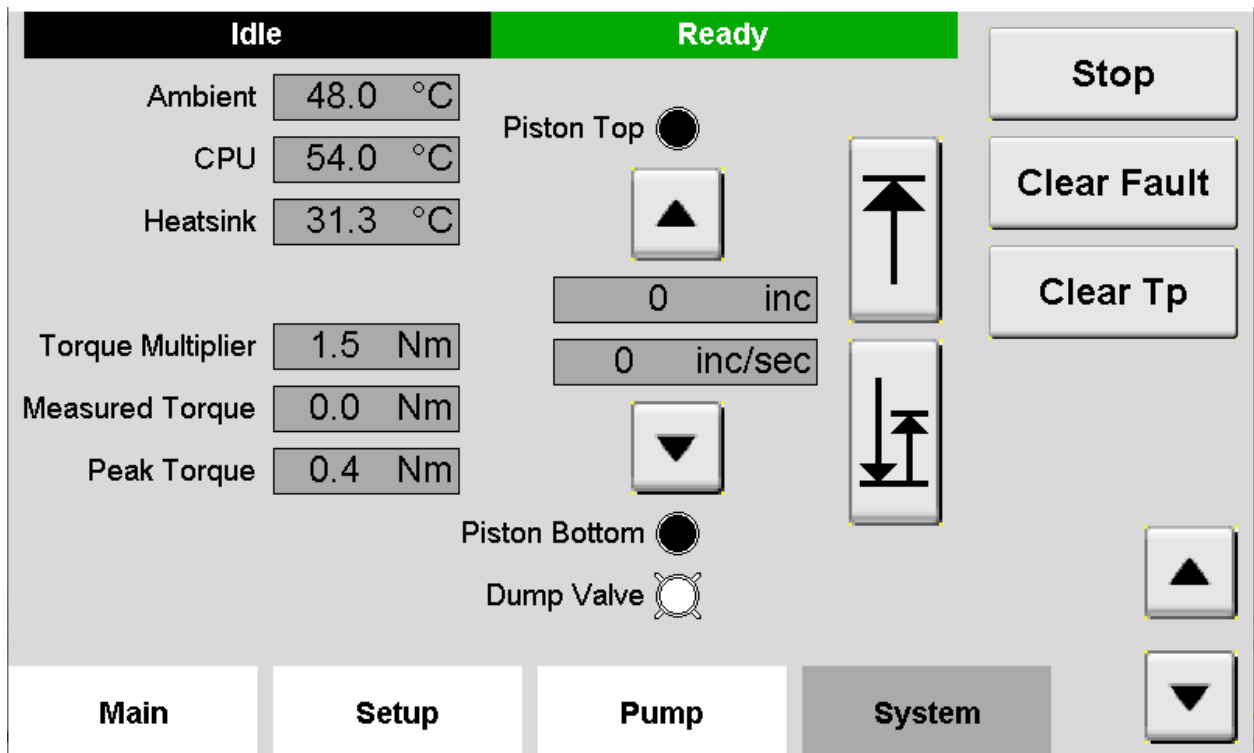

Figure 3.14 Advanced Hardware Screen

3.3 PARAMETER DESCRIPTIONS

Parameters provide configuration, command and status of the Controller. Some of the parameters are universal to all operations (e.g., Torque). Other parameters are specific to a single operation (e.g., Drawback only applies to Production operations).

All Parameters, their type, and their ranges are listed in Appendix A. Each Parameter has an ID number, noted in this manual by "[P####]" with the "####" replaced with the specific Parameter ID. The following subsections provide information for the use of Parameter values and how changing them impacts operation.

Most Parameters are stored in non-volatile memory so they will retain their values through a power cycle. The exception to this is that some Statistic and Operate Parameters are volatile since they are updated continuously by either the Controller or PLC.

3.3.1 Product ID [P001]

The Product ID parameter should be used with the ADI Map Major Version and the ADI Map Minor Version for configuration management.

The Product ID indicates a unique ID for each IVEK Controller type. This parameter may be queried to make sure the expected Controller type is being referenced.

The Product ID of this Controller Module is "2".

3.3.2 ADI Major Version [P002]

The ADI Map Major Version indicates the major version identification of the Parameters. Any change to the Major Version indicates that there are changes to the mapping of Parameters that would be expected to impact the communication with the PLC (e.g., changing the Parameter ID of a parameter).

The ADI Map Major Version as described by the parameter in this manual is "1".

3.3.3 ADI Minor Version [P003]

The ADI Minor Version indicates the minor version identification of the Parameters. Any change to the Minor Version indicates that there are changes to the mapping of Parameters that would not be expected to impact the communication with the PLC (e.g., adding a new parameter to the map).

The ADI Map Minor Version as described by the parameter in this manual is "2".

3.3.4 Firmware Version [P004]

The Firmware Version parameter indicates the IVEK part number and version of the internal Controller firmware.

For example, "560006-0102" or similar

3.3.5 Part Number [P006]

The Part Number parameter indicates the specific part number of the Controller and should match the part number label on the back of the Controller Module.

Value	Description
0	Unconfigured
1	520225-AAAAA , Multiplex Version 3 with US power cord
2	520225-AAAAB , Multiplex Version 3 with International power cord
3	CUSTOM, a Custom Controller Module

3.3.6 Serial Number [P007]

The Serial Number parameter indicates the specific serial number of the Controller and should match the serial number shown on the part number label on the back of the Controller Module.

3.3.7 Commands [P010]

The Commands parameter hold different bits that may be used to control the Controller module and initiate operations. Each bit position(s) represents a different command. Some commands are edge triggered and others are level triggered.

Bit	Name	Value
0	Reserved	Reserved
1	Stop Operation	A rising edge will stop any operation in progress. Note: operations continue to their stopping point after receiving the Stop command, if applicable.
2	Start Production Operation	A rising edge will start a production operation if possible (indicated by Ready, Production status bit equal to 1). The Mode [P050] must be either Dispense, Meter, or MCV for this command to take effect.
3	Start Fluidic Operation	A rising edge will start a fluidic operation if possible (indicated by Ready, Fluidic status bit equal to 1). The Mode [P050] must be either Prime or Agitate for this command to take effect. An exception to this is if the Mode [P050] is Dispense, Meter, or MCV then this command will initiate a Prime operation.
4	Start Reference Operation	A rising edge will start a reference operation if possible (indicated by Ready, Idle status bit equal to 1).
5	Clear Fault	A rising edge will clear the present Fault (indicated by Faulted status bit equal to 1 and a Fault Code not equal to 0).
6	Reserved	Reserved
7	Start Load Operation	A rising edge will start a load operation if possible (indicated by Ready, Load status bit equal to 1).
8 – 12	Reserved	Reserved
13	Start Required	A rising edge will start any presently required operation (e.g., Load Required, Reference Required, Clear Fault).
14 – 31	Reserved	Reserved

3.3.8 Status Flags [P012]

The Status parameters hold different bit flags that indicate the status of the Controller module and operations. Each bit position(s) represents a different status as follows:

Bit	Name	Value
0	Initialized	0 = Multiplex is still initializing from power-up or reset 1 = Multiplex is initialized
1	Configured	0 = Actuator is not configured 1 = Actuator is configured
2	Faulted	0 = No fault 1 = Faulted
3	Reserved	Reserved
4	Motion Disabled	0 = Motion is enabled 1 = Motion is disabled
5	Reference Required	0 = no reference is required 1 = a reference is required before any other operation can be initiated
6	Load Required	0 = no load required 1 = a load is required before a production operation can be initiated
7	All Pumps Disabled	0 = no porting required 1 = a port must be enabled before an operation can be initiated
8	Ready, Idle	0 = The unit is not ready to receive a start signal 1 = The unit is ready to receive a start signal
9	Ready, Production	0 = The unit is not ready to receive a production start signal 1 = The unit is ready to receive a production start signal
10	Ready, Fluidic	0 = The unit is not ready to receive a fluidic start signal 1 = The unit is ready to receive a fluidic start signal
11	Ready, Reference	0 = The unit is not ready to receive a reference start signal 1 = The unit is ready to receive a reference start signal
12	Ready, Load	0 = The unit is not ready to receive a load start signal 1 = The unit is ready to receive a load start signal
13 – 14	Reserved	Reserved
15	Busy Required	0 = The unit does not have any required operations blocking a production operation. 1 = The unit has a required operation blocking a production operation (e.g., Load

Bit	Name	Value
		Required, Reference Required, Faulted)
16	Busy, any operation active	0 = No operations are active 1 = Any operation is active (e.g., production, fluidic, reference, load, porting, etc.)
17	Busy, production	0 = No production operation is active 1 = Production operation (e.g., dispense) is active
18	Busy, fluidic	0 = No fluidic operation is active 1 = Fluidic operation (e.g., prime) is active
19	Busy, reference	0 = No reference operation is active 1 = Reference is active
20	Busy, load	0 = No load operation is active 1 = Load operation is active
21	Busy, port	0 = No porting operation is active 1 = Porting operation is active
24	Reserved	Reserved
25	Chamber Full	0 = Piston is not at the full chamber position 1 = Piston is at the full chamber position
26	Success Pulse	1 = Pulse indicating last dispense was successfully completed (i.e., no faults). Pulse length determined by Post-op dwell setting.
27	Success Last	0 = Last dispense was not successfully completed (i.e., a fault occurred or the dispense was stopped short, or no dispenses have occurred since power-up) 1 = Last dispense was successfully completed (i.e., no faults)
28 – 31	Reserved	Reserved

3.3.9 Status Flags Extended [P013]

The Status Extended parameter hold different bit flags that indicate the status of the Controller module and operations. Each bit position(s) represents a different status as follows:

Bit	Name	Value
0	Dwelling Active	0 = Dwell is not active 1 = Any pump type, a dwell is active
1	Discharging	0 = Discharge portion of operation is not active 1 = Discharge portion of the present operation is active (includes discharge portion only).
2	Intaking	0 = Intake portion of operation is not active 1 = Intake portion of the present operation is active.
3	Piston Moving During Intake	0 = Piston is not moving during the intake portion of the present operation. 1 = Piston is moving during the intake portion of the present operation.
4	Valve Moving During Intake	0 = Valve is not moving during the intake portion of the present operation. 1 = Valve is moving during the intake portion of the present operation.
5	Drawback Dwell Active	0 = Drawback dwell portion of operation is not active. 1 = Drawback dwell portion of operation is active.
6	Drawback	0 = Drawback portion of operation is not active. 1 = Drawback portion of operation is active.
7	Reserved	Reserved
8	Reserved	Reserved
9	Agitate Dwell	0 = Agitate dwell portion of operation is not active. 1 = Agitate dwell portion of operation is active.
10 – 15	Reserved	Reserved
16	Port 1 Fault	0 = Port 1 is not faulted 1 = Port 1 is faulted
17	Port 2 Fault	0 = Port 2 is not faulted 1 = Port 2 is faulted
19	Port 3 Fault	0 = Port 3 is not faulted 1 = Port 3 is faulted
19	Port 4 Fault	0 = Port 4 is not faulted 1 = Port 4 is faulted
20	Port 5 Fault	0 = Port 5 is not faulted 1 = Port 5 is faulted
21	Port 6 Fault	0 = Port 6 is not faulted 1 = Port 6 is faulted
22	Port 7 Fault	0 = Port 7 is not faulted 1 = Port 7 is faulted

23	Port 8 Fault	0 = Port 8 is not faulted 1 = Port 8 is faulted
24	Port 9 Fault	0 = Port 9 is not faulted 1 = Port 9 is faulted
25	Port 10 Fault	0 = Port 10 is not faulted 1 = Port 10 is faulted
26	Port 11 Fault	0 = Port 11 is not faulted 1 = Port 11 is faulted
27	Port 12 Fault	0 = Port 12 is not faulted 1 = Port 12 is faulted
28	Port 13 Fault	0 = Port 13 is not faulted 1 = Port 13 is faulted
29	Port 14 Fault	0 = Port 14 is not faulted 1 = Port 14 is faulted
30	Port 15 Fault	0 = Port 15 is not faulted 1 = Port 15 is faulted
31	Port 16 Fault	0 = Port 16 is not faulted 1 = Port 16 is faulted

3.3.10 State [P014]

The State parameter indicates the present operation state. Some operations only have 1 state (e.g., Priming). However, some operations have multiple states (e.g., Dispense operations may include: Pre-op Dwell, Dispensing, Drawback Dwell, Drawback, Post-op Dwell).

Bit	State	Description
0	Idle	No operations active
1	Priming	Prime operation is active
2	Dispensing	Dispense operation is active, discharge portion
3	Metering	Meter operation is active, discharge portion
4	Drawback Dwell	Dispense/meter operation is active, drawback dwell portion
5	Drawback	Dispense/meter operation is active, drawback portion
6	Faulted	A fault condition exists, must clear fault before operation possible
7	Referencing	A reference operation is active
8	Initializing	Unit is initializing
9	Pre operation Dwell	Dispense/meter operation is active, pre-op dwell portion
10	Post operation Dwell	Dispense/meter operation is active, post-op dwell portion
11	Reserved	Reserved
12	Isolating	Agitate operation is active, isolation volume portion
13	Agitating	Agitate operation is active, active forward/reverse portion
14	Returning	Agitate operation is active, returning back to starting point
15	Bubble Clear	Bubble clear operation is active
16	Loading	Load operation is active
17	Changing Port	Port change operation is active
18	Agitate Dwell	Agitate operation is active, dwelling between forward/reverse portions
19	Reserved	Reserved
20	Reserved	Reserved
21	Reserved	Reserved
22	Motion Locked	Motion is locked, no operations possible until unlocked
23	Not Configured	A Pump Motor is not selected
24	Reserved	Reserved
25	Reserved	Reserved
26	Fault Clear	A fault is being cleared
27	Intaking	Dispense/meter operation is active that requires more than a single chamber volume, intake (reload) portion active
28	Jogging	Maintaining operation is active

3.3.11 Fault Code [P015]

The Fault Code parameter displays faults which are a result of the system detecting improper operation of the

Controller Module or Actuator Module. The HMI will provide text further describing the specific fault condition. The 'clear faults' command must be used before any subsequent operation of the affected controller is performed.

Fault	Name	Description
0	No Faults	No faults are present in the Controller or Actuator
61000	Other Controller	Reserved
61001	Linear Sensor	The linear sensor was either not detected or detected at an unexpected location.
61002	Rotary Sensor	The rotary sensor was either not detected or detected at an unexpected location.
61003	Linear Stall	The motor driver is indicating a motor stall.
61004	Rotary Stall	The rotary sensors indicate a valve has stalled.
61005	Servo Drive	The servo drive is indicating a fault.
61010	Control Cable	A fault exists with one or both of the control cables (Cable A, Cable B)
61015	Motor Hardware	There is a fault with the servo drive or motor.
61016	Internal Software	An unexpected software path was encountered.

3.3.12 Actuator Number [P020]

The Actuator Number parameter allows selection of the various actuators that may be used with the Controller Module. This determines internal system operating points and influences the acceptable ranges of other Parameters.

Bit	Name	Value
0	None	No Actuator selected
1	SF8	Model Number 202394 - Small Frame 8 channel Actuator selected
2	SF10	Model Number 202393 - Small Frame 10 channel Actuator selected
3	SF12	Model Number 202392 - Small Frame 12 channel Actuator selected
4	LF8	Model Number 202397 - Large Frame 8 channel Actuator selected
5	LF10	Model Number 202396 - Large Frame 10 channel Actuator selected
6	LF12	Model Number 202395 - Large Frame 12 channel Actuator selected

WARNING

It is necessary the Actuator Module attached to the Controller Module matches the actuator selected by the Actuator Number parameter. A mismatch of the Actuator Number parameter and the attached Actuator Module could result in both improper operation and overheating of the actuator. The selected Actuator Model Number part number MUST match the attached motor part number in both the base model number portion and any non “#” tabulation fields.

3.3.13 Pump Chamber Volume [P024]

The Pump Chamber Volume parameter indicates how much fluid a full pump chamber contains. For a Multiplex this is a read-only parameter and is always 40,000 increments.

3.3.14 Pump Volume Resolution [P025]

The Pump Volume Resolution parameter is a read-only parameter that indicates the ideal volume resolution of the attached actuator and pump combination. All entered volume parameters in the Controller must be a multiple of this resolution. For a Multiplex this value is always 1 increment.

3.3.15 Pump Rate Resoution [P026]

The Pump Rate Resolution parameter is a read-only parameter that indicates the ideal rate resolution of the attached motor/base or actuator and pump combination. All entered rate parameters in the Controller must be a multiple of this resolution. For a Multiplex this is value is always 1 increment per second.

3.3.16 Running Torque [P031]

The Running Torque parameter determines what percentage of maximum specified current is delivered to the motor while the motor is moving. This percentage is relative to the specified current of the Motor rather than relative to the overall capability of the drive.

Typically, this should be left at the default value.

3.3.17 Valve Dwell [P042]

The Valve Dwell parameter sets the amount of time to dwell before sensing valve motion.

Typically, this should be left at the default value. It may need to be increased with viscous fluids that cause a slower response time of the valve.

3.3.18 Reference Rate [P043]

The Reference Rate is the rate of movement while referencing.

Typically, this should be left at the default value.

3.3.19 Pumps Enabled [P044]

The Pumps Enabled parameter enables the pumps installed in the Actuator Module. Pump 1 is located on the right side of the actuator and the numbering moves to the left.

Bit	Name	Value
0	Pump 1 Enabled (used for all Actuators)	0 = Pump 1 Disabled 1 = Pump 1 Enabled
1	Pump 2 Enabled (used for all Actuators)	0 = Pump 2 Disabled 1 = Pump 2 Enabled
2	Pump 3 Enabled (used for all Actuators)	0 = Pump 3 Disabled 1 = Pump 3 Enabled
3	Pump 4 Enabled (used for all Actuators)	0 = Pump 4 Disabled 1 = Pump 4 Enabled
4	Pump 5 Enabled (used for all Actuators)	0 = Pump 5 Disabled 1 = Pump 5 Enabled
5	Pump 6 Enabled (used for all Actuators)	0 = Pump 6 Disabled 1 = Pump 6 Enabled
6	Pump 7 Enabled (used for all Actuators)	0 = Pump 7 Disabled 1 = Pump 7 Enabled
7	Pump 8 Enabled (used for all Actuators)	0 = Pump 8 Disabled 1 = Pump 8 Enabled
8	Pump 9 Enabled (used for SF10, SF 12, LF10 and LF12 Actuators)	0 = Pump 9 Disabled 1 = Pump 9 Enabled
9	Pump 10 Enabled (used for SF10, SF 12, LF10 and LF12 Actuators)	0 = Pump 10 Disabled 1 = Pump 10 Enabled
10	Pump 11 Enabled (used for SF12 and LF12 Actuators)	0 = Pump 11 Disabled 1 = Pump 11 Enabled
11	Pump 12 Enabled (used for SF12 and LF12 Actuators)	0 = Pump 12 Disabled 1 = Pump 12 Enabled
12	Pump 13 Enabled	Reserved for future use
13	Pump 14 Enabled	Reserved for future use
14	Pump 15 Enabled	Reserved for future use
15	Pump 16 Enabled	Reserved for future use

3.3.20 Pumps Installed [P045]

The Pumps Installed parameter is a read-only parameter that indicates the pumps installed in the Actuator Module. Pump 1 is located on the right side of the actuator and the numbering moves to the left.

Bit	Name	Value
0	Pump 1 Installed (used for all Actuators)	0 = Pump 1 Not Installed 1 = Pump 1 Installed
1	Pump 2 Installed (used for all Actuators)	0 = Pump 2 Not Installed 1 = Pump 2 Installed
2	Pump 3 Installed (used for all Actuators)	0 = Pump 3 Not Installed 1 = Pump 3 Installed
3	Pump 4 Installed (used for all Actuators)	0 = Pump 4 Not Installed 1 = Pump 4 Installed

4	Pump 5 Installed (used for all Actuators)	0 = Pump 5 Not Installed 1 = Pump 5 Installed
5	Pump 6 Installed (used for all Actuators)	0 = Pump 6 Not Installed 1 = Pump 6 Installed
6	Pump 7 Installed (used for all Actuators)	0 = Pump 7 Not Installed 1 = Pump 7 Installed
7	Pump 8 Installed (used for all Actuators)	0 = Pump 8 Not Installed 1 = Pump 8 Installed
8	Pump 9 Installed (used for SF10, SF 12, LF10 and LF12 Actuators)	0 = Pump 9 Not Installed 1 = Pump 9 Installed
9	Pump 10 Installed (used for SF10, SF 12, LF10 and LF12 Actuators)	0 = Pump 10 Not Installed 1 = Pump 10 Installed
10	Pump 11 Installed (used for SF12 and LF12 Actuators)	0 = Pump 11 Not Installed 1 = Pump 11 Installed
11	Pump 12 Installed (used for SF12 and LF12 Actuators)	0 = Pump 12 Not Installed 1 = Pump 12 Installed
12	Pump 13 Installed	Reserved for future use
13	Pump 14 Installed	Reserved for future use
14	Pump 15 Installed	Reserved for future use
15	Pump 16 Installed	Reserved for future use

3.3.21 Mode [P050]

The Mode parameter determines which operating sequence will be performed when a either a Production Start command or a Fluidic Setup Start Command is initiated. These operating modes are described above in the Operation section.

A Production Start command is ignored if the Mode is presently set to a Disabled, Prime, or Agitate. A Fluidic Start command is ignored if the Mode is presently set to Disabled. If the mode is presently set to Production Mode (i.e., Dispense, Meter, or MCV), a Fluidic Start command will initiate a Prime operation.

Value	Name	Value
0	Disabled	System is disabled
1	Prime	System set to operate in Prime Mode (Fluidic)
2	Dispense	System set to operate in Dispense Mode (Production)
3	Meter	System set to operate in Meter Mode (Production)
4	Agitate	System set to operate in Agitate Mode (Fluidic)
5	MCV	System set to operate in MCV Mode (Productdion)

3.3.22 Direction [P051]

The Production/Fluidic Setup Direction parameter determines which direction the fluid will move relative to the Discharge Port during an operation.

Bit	Name	Value
0	Reverse	Fluid moves from the discharge port (outlet) to the intake port (inlet)
1	Forward	Fluid moves from the intake port (inlet) to the discharge port (outlet)

3.3.23 Dispense Volume [P052]

The Dispense Volume parameter determines how much fluid is discharged during Dispense or MCV operations. The Dispense Volume parameter is in units of increment. The minimum value is 0 for no dispense and the maximum value is 40000 for the maximum dispense (entire chamber volume). Any value of “X” in between the min and max dispenses X/40000 of the pump chamber. The Dispense Volume has no effect in Meter, Prime or Agitate modes.

3.3.24 Dispense Rate [P053]

The Dispense Rate parameter determines the rate at which the fluid moves out of the discharge port (outlet) in increments per second.

3.3.25 Drawback Volume [P055]

The Drawback Volume determines the amount of fluid to move backwards after a dispense operation. Typically, this is configured for a small fraction of the dispense volume. Drawback allows fluid to move in the opposite direction at the end of an operation to better separate the fluid at the tip. Often, high viscosity or “stringy” fluids are susceptible to poor separation at the end of a dispense. Drawback provides a snapping motion in the fluid to attempt to shear it off at the tip.

3.3.26 Drawback Rate [P056]

The Drawback Rate parameter determines the rate of fluid movement during the drawback portion of a Production operation if P055 is greater than zero (0).

3.3.27 Drawback Dwell [P057]

The Drawback Dwell parameter determines the amount of time the fluid movement pauses between the end of the discharge portion of the operation and the beginning of the drawback portion of the operation if P055 is greater than zero (0).

Depending on the inertia of the pump and fluid, small dwell times may not give the pump enough time to settle between direction changes, resulting in a stall.

3.3.28 Load Mode [P058]

The Load Mode parameter determines which Load mode is configured for the present Production operation as well as influences the decision as to when a Load is required (see description of Load Modes above). When a Load is required, a Production operation will be inhibited from starting.

Bit	Name	Value
0	Manual	Loads only when commanded
1	Empty	Loads when the chamber is empty
2	Every	Loads after every cycle

3.3.29 Pre-op Dwell [P065]

The Pre-Op Dwell parameter allows the configuration of a dwell time before the Production operation, after a Start Command is received. This dwell time may be used in conjunction with certain status signals to perform other operations during the dwell time.

An example of this is to energize a valve with enough time for it to fully open before pumping fluid.

3.3.30 Post-op Dwell [P066]

The Post-Op Dwell parameter allows the configuration of a dwell time after the Production operation. This dwell time may be used in conjunction with certain status signals to perform other operations during the dwell time.

An example of this is to delay the de-energization of a valve with enough time for pumping fluid to stop moving before the valve starts to close.

3.3.31 Agitate Volume [P082]

The Agitate Volume parameter sets the volume to displace during each cycle of an Agitate operation. The volume is in units of full strokes. The Agitate Volume will be traversed in both the forward and reverse direction after the isolation volume is traversed.

3.3.32 Prime/Load Rate [P083]

The Prime/Load Rate parameter sets the rate at which to move the piston during a Prime operation. This parameter also sets the rate at which to move the piston during a Load operation. The rate is in units of increments per second.

3.3.33 Agitate Dwell [P085]

The Agitate Dwell parameter provides an adjustable wait time between each reverse and forward cycle of an Agitate operation.

3.3.34 Agitate Isolation Volume [P086]

The Agitate Isolation Volume parameter determines the amount of fluid to move back into Discharge Port before starting the Agitate back and forth sequences. This provides an air barrier between the end of the fluid in the tubing and the tip. The volume is in units of full strokes.

3.3.35 Prime Duration [P087]

The Prime Duration parameter sets the maximum amount of time to run a Prime operation. Typically, a Prime operation duration is controlled by the Fluidic Start and Stop signal. The Prime Duration provides a maximum operating time allowed to eliminate the possibility of an endless operation. The units of the Prime Duration is seconds.

3.3.36 Total Volume [P090]

The Total Volume parameter is a read-only parameter that indicates the total production volume since last power cycle. The units of the Total Volume is increments.

3.3.37 Volume Position [P092]

The Volume Position parameter is read-only and indicates the present position of the pump. The full pump chamber position (also, the reference position) is increment 0. The empty pump position is increment 40,000.

3.3.38 Volume Remaining [P093]

The volume Remaining parameter is read-only and indicates the remaining chamber volume, based on the present position. When the piston is at the full pump chamber position (i.e., the reference position) the volume remaining is 40,000. When the piston is at the empty pump chamber position, the volume remaining is 0.

3.3.39 Total Cycles [P095]

The Total Cycles parameter is read-only and indicates the total production cycle.

3.3.40 HMI Lock Configuration [P127]

The HMI Lock Configuration parameter is used to set the access level for the touchscreen parameters. The setting determines the access. This may be used to lock out an operator from certain features of the Controller.

Bit	Name	Value
0	Lock Most Values	Locks out the ability to change most of the touchscreen values
1	Lock Pushbuttons	Locks out the ability to use the pushbuttons
2	Lock Direction	Locks out the ability to change the fluid direction
3	Lock Mode	Locks out the ability to change the Mode

3.3.41 Erase Parameters [P138]

The Erase Parameters parameter will reset the parameters of the Controller to the factory default values.

3.3.42 Logic In 1 Configuration [P160]**3.3.43 Logic In 2 Configuration [P161]****3.3.44 Logic In 3 Configuration [P162]****3.3.45 Logic In 4 Configuration [P163]****3.3.46 Logic In 5 Configuration [P164]**

The Logic In Configuration parameters allows for configuration of each of the five inputs to provide a different function. The inputs are active when voltage is present (i.e., true) and inactive when voltage is absent (i.e., false).

Bit	Name	Value
0	<DISABLED>	Changes on the input signal are ignored.
1	<ENABLE> Motion	Not used.
2	<TRIGGER> Stop Operation	Same as Commands [P010] bit 1.
3	<TRIGGER> Production Operations	Same as Commands [P010] bit 2.
4	<TRIGGER> Fluidic Operations	Same as Commands [P010] bit 3.
5	<TRIGGER> Reference	Same as Commands [P010] bit 4.
6	<TRIGGER> Clear Fault	Same as Commands [P010] bit 5.
7	<TRIGGER> Clear Alert	Same as Commands [P010] bit 6.
8	<TRIGGER> Load	Same as Commands [P010] bit 7.
9	<CROSSOVER> Synchronous	Not used.
10	<TRIGGER> Park Port	Not used.
11	<TRIGGER> Unpark Port	Not used.
13	<TRIGGER> Piston Unstick	Not used.
14	<TRIGGER> Clear Required	Same as Commands [P010] bit 13.
15	<GATE> Production Operations	Same as Commands [P010] bit 14.
16	<GATE> Fluidic Operations	Same as Commands [P010] bit 15.
17	<LOCK> Front Panel	An inactive signal on the input locks the front panel based on the Front Panel Lock configuration.

3.3.47 Logic In 1 Invert [P172]**3.3.48 Logic In 2 Invert [P173]****3.3.49 Logic In 3 Invert [P174]****3.3.50 Logic In 4 Invert [P175]****3.3.51 Logic In 5 Invert [P176]**

The Logic In 1 Invert – Logic In 5 Invert parameters, when enabled, inverts the Logic In input from active when voltage applied to active when voltage is not applied.

3.3.52 Logic In 1 [P184]**3.3.53 Logic In 2 [P185]****3.3.54 Logic In 3 [P186]****3.3.55 Logic In 4 [P187]****3.3.56 Logic In 5 [P188]**

The Logic In 1 – Logic In 5 parameters indicate the present state of the Logic In input.

3.3.57 Start I/O Test [P197]

The Start I/O Test parameter allows for overriding the Logic Out signals and monitoring the Logic In signals in order to either verify or troubleshoot the Logic I/O connections to the controller.

3.3.58 Logic Out 1 Configuration [P200]**3.3.59 Logic Out 2 Configuration [P201]****3.3.60 Logic Out 3 Configuration [P202]****3.3.61 Logic Out 4 Configuration [P203]****3.3.62 Logic Out 5 Configuration [P204]****3.3.63 Logic Out 6 Configuration [P205]**

The Logic Out 1 Configuration – Logic Out 6 Configuration parameters provide a programmable output allowing for configuration of each of the six outputs to provide a different function. The outputs conduct when active (i.e., true) and do not conduct when inactive (i.e., false).

Bit	State	Description
0	<DISABLED>	Output does not change state during operations.
1	<READY> Initialized	Same as Status Flag [P012] bit 0.
2	<READY> Configured	Same as Status Flag [P012] bit 1.
3	<STATUS> Fault	Same as Status Flag [P012] bit 2.
4	<STATUS> Alert	Same as Status Flag [P012] bit 3.
5	<STATUS> Motion Disabled	Same as Status Flag [P012] bit 4.
6	<STATUS> Reference Required	Same as Status Flag [P012] bit 5.
7	<STATUS> Load Required	Same as Status Flag [P012] bit 6.
8	<STATUS> Port Required	Same as Status Flag [P012] bit 7.

9	<READY> Idle	Same as Status Flag [P012] bit 8.
10	<READY> Production	Same as Status Flag [P012] bit 9.
11	<READY> Fluidic Setup	Same as Status Flag [P012] bit 10.
12	<READY> Reference	Same as Status Flag [P012] bit 11.
13	<READY> Load	Same as Status Flag [P012] bit 12.
14	<READY> Park	Same as Status Flag [P012] bit 13.
15	<READY> Unpark	Same as Status Flag [P012] bit 14.
16	<STATUS> Operation Required	Same as Status Flag [P012] bit 15.
17	<BUSY> Any Operation	Same as Status Flag [P012] bit 16.
18	<BUSY> Production Operation	Same as Status Flag [P012] bit 17.
19	<BUSY> Fluidic Setup Operation	Same as Status Flag [P012] bit 18.
20	<BUSY> Reference Operation	Same as Status Flag [P012] bit 19.
21	<BUSY> Load Operation	Same as Status Flag [P012] bit 20.
22	<BUSY> Porting Operation	Same as Status Flag [P012] bit 21.
23	<BUSY> Park Operation	Same as Status Flag [P012] bit 22.
24	<BUSY> Autotrigger Active	Same as Status Flag [P012] bit 23.
25	<STATUS> Parked	Same as Status Flag [P012] bit 24.
26	<STATUS> Chamber Full	Same as Status Flag [P012] bit 25.
27	<SUCCESS> Pulse	Same as Status Flag [P012] bit 26.
28	<SUCCESS> Last	Same as Status Flag [P012] bit 27.
29	<BUSY> Dwell	Same as Status Flag Extended [P013] bit 0.
30	<BUSY> Discharge	Same as Status Flag Extended [P013] bit 1.
31	<BUSY> Intake	Same as Status Flag Extended [P013] bit 2.
32	<BUSY> Intake Piston	Same as Status Flag Extended [P013] bit 3.
33	<BUSY> Valve	Same as Status Flag Extended [P013] bit 4.
34	<BUSY> Drawback Dwell	Same as Status Flag Extended [P013] bit 5.
35	<BUSY> Drawback	Same as Status Flag Extended [P013] bit 6.
36	<BUSY> Agitate Dwell	Same as Status Flag Extended [P013] bit 9.

3.3.64 Logic Out 1 Invert [P212]**3.3.65 Logic Out 2 Invert [P213]****3.3.66 Logic Out 3 Invert [P214]****3.3.67 Logic Out 4 Invert [P215]****3.3.68 Logic Out 5 Invert [P216]****3.3.69 Logic Out 6 Invert [P217]**

Logic Out 1 Invert – Logic Out 6 Invert, when enabled, inverts the output from conducting when active to not conducting when active.

3.3.70 Logic Out 1 [P224]**3.3.71 Logic Out 2 [P225]****3.3.72 Logic Out 3 [P226]****3.3.73 Logic Out 4 [P227]****3.3.74 Logic Out 5 [P228]****3.3.75 Logic Out 6 [P229]**

Logic Out 1 – Logic Out 6 force the state of the Logic Out outputs to this value during I/O Test mode.

3.4 REAR PANEL CONNECTIONS**3.4.1 LOGIC I/O Interface**

The LOGIC I/O Interface provides connections between the Controller Module and the customer's PLC. Configurable inputs allow such signals as ready and fault signals to be communicated to and from the PLC.

3.4.1.1 Signal Functions

Logic In 1 - 5 - The Logic In 1 – 5 inputs provide five configurable input signals (Logic In 1, Logic In 2, Logic In 3, Logic In 4, Logic In 5) configurable in the Logic In System screen. The inputs can be configured by modifying the Logic In Configuration parameters ([P160 – P164]). The logic of each Logic In input may also be inverted using the Logic In Invert parameters ([P172 – P176]).

The Logic In inputs are isolated from each other.

All inputs accept a 24 VDC signal and require 4 mA.

Logic Out 1 - 6 - The Logic Out 1 – 6 outputs provide six configurable output signals (Logic Out 1, Logic Out 2, Logic Out 3, Logic Out 4, Logic Out 5, Logic Out 6) configurable in the Logic Out System screen. The outputs can be configured by modifying the Logic Out Configuration parameters ([P200 – P204]). The logic of each Logic Out output may also be inverted using the Logic Out Invert parameters ([P212 – P217]).

The Logic Out outputs are isolated from each other.

For further description of the input and output electrical characteristics and wiring please see Technical Bulletin 134 (TB-134).

3.4.1.2 Connections

All connections are through a 24-pin circular plastic connector, with the mating connector (TE # 206837-1), backshell (TE # 206138-1), pins (TE # 66105-4), and key (TE # 200821-1) supplied with the unit. Table 3.1 shows the connector pin layout.

Table 3.1 LOGIC I/O Interface

PIN	SIGNAL	PIN	SIGNAL
1	LOGIC IN 1 +	13	LOGIC IN 3 +
2	LOGIC IN 1 -	14	LOGIC IN 3 -
3	LOGIC OUT 1 +	15	LOGIC OUT 4 +
4	LOGIC OUT 1 -	16	LOGIC OUT 4 -
5	LOGIC OUT 2 +	17	LOGIC OUT 5 +
6	LOGIC OUT 2 -	18	LOGIC OUT 5 -
7	LOGIC OUT 3 +	19	LOGIC OUT 6 +
8	LOGIC OUT 3 -	20	LOGIC OUT 6 -
9	LOGIC IN 2 +	21	LOGIC IN 4 +
10	LOGIC IN 2 -	22	LOGIC IN 4 -
11	Key	23	LOGIC IN 5 +
12	Key	24	LOGIC IN 5 -

3.4.2 RS-232 Interfaces

The RS-232 serial interface provides control of all functions available. The hardware is configured as RS-232 Data Communication Equipment (DCE) standard with the pin configuration shown in Table 3.2. Connecting to other DTE equipment, such as a computer or PLC, requires a straight through cable.

Table 3.2 RS-232 Connections (DCE, 9 pin D-sub male)

Pin	Signal	Direction
1	NC	not connected
2	TXD	Data to DTE
3	RXD	Data from DTE
4	NC	not connected
5	COM	Common
6	NC	not connected
7	NC	not connected
8-9	NC	not connected

No hardware signals are currently used for handshaking.

The parameters of the communications interface are as follows.

- 9600 BAUD
- 8 BIT
- NO PARITY
- ONE STOP BIT

After a dispense or metering operation is triggered, the values for that operation are fixed. This allows new parameter values for the following operation to be downloaded before the current operation is complete.

The Controller Module serial protocol is a query/response protocol. The interface does not 'broadcast' messages, such as fault conditions, but only responds when it receives a command.

3.4.2.1 Command Structure

The command is a string of ASCII characters. The use of the ASCII backspace or rubout characters as a means of entry correction is not supported.

Commands are not directly echoed as they are received. The terminal being utilized to send commands should be setup for half-duplex or local echo mode.

After dispense or metering operation is triggered, the values for that operation are fixed. This allows new parameter values for the following operation to be downloaded before the current operation is complete.

The Controller Module serial interface does not 'broadcast' messages, such as fault conditions, but only responds when it receives a command.

<name> Represents an argument
 [] Represents an optional argument
 , Field delimiter character for numerical arguments.
 <CR> End of command represented by ASCII carriage return character (no line feed).

The complete command form is:

```
[<ctrl>]<cmd>[<value1>[,<value2>[,<value3>]]]<CR>
```

<ctrl> Controller number

All numerical characters beginning a command are evaluated as the controller number. If omitted, the previous value of the controller remains in effect. The value of zero will broadcast a command to all controllers. Controllers are within the range from 1 to 8 (with the exception of a Multiplex Striper Controller which for compatibility with other IVEK equipment is addressed as 31).

<cmd> Command

The first non-numerical character seen in the command string will be evaluated as the command character. Command characters ARE case sensitive (lower case). If no command is included, (command string only consists of numerical characters), response will only be <CR> indicating unit is ready to accept new command string.

<value1> First numerical parameter

The first numerical character received after the command character begins evaluation of the first numerical parameter. A field delimiter character after the command character and before the first numerical character will be ignored and will not delimit the first parameter to a value of zero. This means a zero character must be used to indicate an argument with value of zero for the first numerical parameter.

<value2> Second numerical parameter

All non-numerical values with the exception of the field delimiter character will be ignored. A null argument will be evaluated as a value of zero (no numerical characters between the field delimiter for the first parameter and a following field delimiter or end of command character).

<value3> Third numerical parameter

All non-numerical values with the exception of the field delimiter character will be ignored. A null argument will be evaluated as a value of zero (no numerical characters between the field delimiter for the second parameter and a following field delimiter or end of command character). All values in the command string which are not required by the command specified will be ignored.

All values in the command string which are not required by the command specified will be ignored. Following are some examples of command strings.

2v890<CR> Controller 2, command v, one value of 890
 0r400<CR> All controllers, command r, one value of 400
 e<CR> Same controller as previous command, command e
 1q<CR> Controller 1, command q, no values

NOTE

Transmission should stop when an ASCII carriage return character is sent and can resume when the ASCII carriage return of the response is received. The serial interface has a limited receive buffer. Information may be lost if multiple commands are sent one after another without waiting for the ASCII carriage return response.

3.4.2.2 Response String

The response from the Multiplex has a format which is very similar to the command sent with the addition of a 'flag' and value if a fault or warning is active.

<name> Represents an argument
 [] Represents an optional argument
 , Field delimiter character for numerical arguments.
 * Field delimiter character which precedes fault or warning value
 <CR> End of command represented by ASCII carriage return character (no line feed).

[<cntrl>]<cmd>[<value1>[,<value2>[,<value3>]]]<CR>

The description for the response string above follows the structure of the command string previously described.

If a fault or warning exists, the normal value(s) are returned for the command, followed by the fault delimiter (in place of the normal field delimiter) and the fault number to indicate the problem. The fault delimiter and fault number will appear in all responses from that controller until the command to clear faults is sent to the faulted controller. If a command normally returns three values, the fault number will replace the third value. Following are some examples of command strings.

2c<CR>

Command: Controller 2, command

c 2c<CR>

Response: Controller 2, command c, no values other than warnings or first fault (subsequent faults are cleared) are returned by command c.

1m1<CR>

Command: Controller 1, command m, one value of

1 1m1<CR>

Response: Controller 1, command m, one value of 1

u<CR>

Command: Same Controller as previous command (1), command u, no new value 1u2000<CR>

Response: Controller 1, command u, one value of 2000

u3500<CR>

Command: Same Controller as previous command (1), command u, 1 value of 3500 1u3500<CR>

Response: Controller 1, command u, value of 3500

r0<CR>

Command: Same Controller as previous command (1), command r, 1 value of 0 1r1000*2

Response: Controller 1, command r, current value is 1000 (unchanged), warning 2 = value no good

3.4.2.3 Commands

The command set controls the overall settings of the system. Most commands allow reading/writing of parameters. Parameters that may be modified via RS232 are listed in Appendix A along with their corresponding commands. Table 3.3 list the commands.

NOTE

Refer to previous description for complete command syntax (“COMMAND STRUCTURE”).

<value3> has been omitted from the response in this table, but will either be a 0 if no faults or warnings exist or will provide the fault or warning number.

Table 3.3 Commands

<u>Command</u>	<u>Response</u>	<u>Description</u>
a => AUTOLOAD		
a	a<value1>	Returns the present Load Mode parameter value [P058].
a<value1>	a<value1>	Sets the Lode Mode parameter value [P058]. <value1>: 0 = Manual (default) 1 = Empty 2 =Every
b => BEGIN		
b	b	Initiates a prime, dispense, or meter cycle according to the current ‘mode’ setting. Equivalent to setting bits 2 & 3 of the Command parameter [P010].
c => CLEAR FAULTS		
c	c<value1>	Clears all faults. Fault Code [P015] returned as value1. Equivalent to setting bit 5 of the Command Parameter [P010].
d => DIRECTION		
d	d<value1>	Returns the present Direction parameter [P051].
d<value1>	d<value1>	Sets the present Direction parameter [P051]. <value1>: 0 = Reverse 1 = Forward (default)
e => END		
e	e	Stops current pump operation. In Prime mode, will continue until piston chamber is full. In Agitate mode, will continue until fluid is in the original position. In all other modes, motion will stop as soon as possible. Equivalent to setting bit 1 of the Command Parameter [P010].
f => REFERENCE		
f	f	References the home position for both the rotary and linear sensors for all enabled controllers and pump modules. Equivalent to setting bit 4 of the Command Parameter [P010].
g => TOTALIZER		
g	g<value1>	Returns the present Totalizer Volume parameter [P090].
g0	g0,<value2>	Returns the present Totalizer Volume parameter [P090]. Maximum: The totalizer will Increment to a maximum value of 2,000,000,000 and stop. The totalizer will not ‘wrap around’. The pump will continue to operate without incrementing the totalizer. Note: sending “g0,0” resets the totalizer to 0.
g1	g1,<value2>	Returns the present Totalizer Cycles parameter [P095]. Maximum: The totalizer will Increment to a maximum value of 2,000,000,000 and stop. The totalizer will not ‘wrap around’. The pump will continue to operate without incrementing the totalizer.

Note: sending "g1,0" resets the totalizer to 0.

h =>HARDWIRED READY SIGNAL

h11 h11,<value2>Returns the present Logic In 1 Configuration parameter [P160].
 h11,<value2> h11,<value2>Sets the present Logic In 1 Configuration parameter [P160].
 h12 h12,<value2>Returns the present Logic In 2 Configuration parameter [P161].
 h12,<value2> h12,<value2>Sets the present Logic In 2 Configuration parameter [P161].
 h13 h13,<value2>Returns the present Logic In 3 Configuration parameter [P162].
 h13,<value2> h13,<value2>Sets the present Logic In 3 Configuration parameter [P162].
 h14 h14,<value2>Returns the present Logic In 4 Configuration parameter [P163].
 h14,<value2> h14,<value2>Sets the present Logic In 4 Configuration parameter [P163].
 h15 h15,<value2>Returns the present Logic In 5 Configuration parameter [P164].
 h15,<value2> h15,<value2>Sets the present Logic In 5 Configuration parameter [P164].

<value2>:

0 = <DISABLED>
 2 = <TRIGGER> Stop Operation ([P010] bit 1)
 3 = <TRIGGER> Production Operations ([P010] bit 2)
 4 = <TRIGGER> Fluidic Operations ([P010] bit 3)
 5 = <TRIGGER> Reference ([P010] bit 4)
 6 = <TRIGGER> Clear Fault ([P010] bit 5)
 8 = <TRIGGER> Load ([P010] bit 6)
 14 = <TRIGGER> Clear Required ([P010] bit 13)
 15 = <GATE> Production Operations ([P010] bit 14)
 16 = <GATE> Fluidic Operations ([P010] bit 15)
 17 = <LOCK> Front Panel

h21 h21,<value2>Returns the present Logic Out 1 Configuration parameter [P200].
 h21,<value2> h21,<value2>Sets the present Logic Out 1 Configuration parameter [P200].
 h22 h22,<value2>Returns the present Logic Out 2 Configuration parameter [P201].
 h22,<value2> h22,<value2>Sets the present Logic Out 2 Configuration parameter [P201].
 h23 h23,<value2>Returns the present Logic Out 3 Configuration parameter [P202].
 h23,<value2> h23,<value2>Sets the present Logic Out 3 Configuration parameter [P202].
 h24 h24,<value2>Returns the present Logic Out 4 Configuration parameter [P203].
 h24,<value2> h24,<value2>Sets the present Logic Out 4 Configuration parameter [P203].
 h25 h25,<value2>Returns the present Logic Out 5 Configuration parameter [P204].
 h25,<value2> h25,<value2>Sets the present Logic Out 5 Configuration parameter [P204].
 h26 h26,<value2>Returns the present Logic Out 6 Configuration parameter [P205].
 h26,<value2> h26,<value2>Sets the present Logic Out 6 Configuration parameter [P205].

<value2>:

0 = <DISABLED>
 1 = <READY> Initialized ([P012] bit 0)
 2 = <READY> Configured ([P012] bit 1)
 3 = <STATUS> Fault ([P012] bit 2)
 4 = <STATUS> Alert ([P012] bit 3)
 5 = <STATUS> Motion Disabled ([P012] bit 4)
 6 = <STATUS> Reference Required ([P012] bit 5)
 7 = <STATUS> Load Required ([P012] bit 6)
 8 = <STATUS> Port Required ([P012] bit 7)
 9 = <READY> Idle ([P012] bit 8)
 10 = <READY> Production ([P012] bit 9)
 11 = <READY> Fluidic Setup ([P012] bit 10)
 12 = <READY> Reference ([P012] bit 11)
 13 = <READY> Load ([P012] bit 12)
 14 = <READY> Park ([P012] bit 13)
 15 = <READY> Unpark ([P012] bit 14)
 16 = <STATUS> Operation Required ([P012] bit 15)
 17 = <BUSY> Any Operation ([P012] bit 16)
 18 = <BUSY> Production Operation ([P012] bit 17)
 19 = <BUSY> Fluidic Setup Operation ([P012] bit 18)
 20 = <BUSY> Reference Operation ([P012] bit 19)
 21 = <BUSY> Load Operation ([P012] bit 20)
 22 = <BUSY> Porting Operation ([P012] bit 21)
 23 = <BUSY> Park Operation ([P012] bit 22)

- 24 = <BUSY> Autotrigger Active ([P012] bit 23)
- 25 = <STATUS> Parked ([P012] bit 24)
- 26 = <STATUS> Chamber Full ([P012] bit 25)
- 27 = <SUCCESS> Pulse ([P012] bit 26)
- 28 = <SUCCESS> Last ([P012] bit 27)
- 29 = <BUSY> Dwell ([P013] bit 0)
- 30 = <BUSY> Discharge ([P013] bit 1)
- 31 = <BUSY> Intake ([P013] bit 2)
- 32 = <BUSY> Intake Piston ([P013] bit 3)
- 33 = <BUSY> Valve ([P013] bit 4)
- 34 = <BUSY> Drawback Dwell ([P013] bit 5)
- 35 = <BUSY> Drawback ([P013] bit 6)
- 36 = <BUSY> Agitate Dwell ([P013] bit 9)

- h31 h31,<value2>Returns the present Logic In 1 Invert parameter [P172].
- h31,<value2> h31,<value2>Sets the present Logic In 1 Invert parameter [P172].
- h32 h32,<value2>Returns the present Logic In 2 Invert parameter [P173].
- h32,<value2> h32,<value2>Sets the present Logic In 2 Invert parameter [P173].
- h33 h33,<value2>Returns the present Logic In 3 Invert parameter [P174].
- h33,<value2> h33,<value2>Sets the present Logic In 3 Invert parameter [P174].
- h34 h34,<value2>Returns the present Logic In 4 Invert parameter [P175].
- h34,<value2> h34,<value2>Sets the present Logic In 4 Invert parameter [P175].
- h35 h35,<value2>Returns the present Logic In 5 Invert parameter [P176].
- h35,<value2> h35,<value2>Sets the present Logic In 5 Invert parameter [P176].

<value2>:
 0 = Disabled (Default)
 1 = Enabled

- h41 h41,<value2>Returns the present Logic Out 1 Invert parameter [P212].
- h41,<value2> h41,<value2>Sets the present Logic Out 1 Invert parameter [P212].
- h42 h42,<value2>Returns the present Logic Out 2 Invert parameter [P213].
- h42,<value2> h42,<value2>Sets the present Logic Out 2 Invert parameter [P213].
- h43 h43,<value2>Returns the present Logic Out 3 Invert parameter [P214].
- h43,<value2> h43,<value2>Sets the present Logic Out 3 Invert parameter [P214].
- h44 h44,<value2>Returns the present Logic Out 4 Invert parameter [P215].
- h44,<value2> h44,<value2>Sets the present Logic Out 4 Invert parameter [P215].
- h45 h45,<value2>Returns the present Logic Out 5 Invert parameter [P216].
- h45,<value2> h45,<value2>Sets the present Logic Out 5 Invert parameter [P216].
- h46 h46,<value2>Returns the present Logic Out 6 Invert parameter [P217].
- h46,<value2> h46,<value2>Sets the present Logic Out 6 Invert parameter [P217].

<value2>:
 0 = Disabled (Default)
 1 = Enabled

k => KEYLOCK

- k k<value1> Returns the present Pumps Enabled parameter [P044].
- k<value1> k<value1> Sets the Pumps Enabled parameter [P044].

<value1>:
 0 = Disable all Pumps within controller and the controller. $2^{12}-1 = 4095$ Enable all Pumps within controller
 255 (Default 8 Channel)
 1023 (Default 10 Channel)
 4095 (Default 12 Channel)

Individual enable / disable functions can be determined using binary coding as follows:

if bit set,	bit	value	Pump Module
	0	1	Enable Pump 1
	1	2	Enable Pump 2
	2	4	Enable Pump 3
	3	8	Enable Pump 4 etc.

l => LOAD

l l Initiates a load cycle.
 Equivalent to setting bit 7 of Command parameter [P010].

m => MODE

m m<value1> Returns the present Mode parameter [P050].

m<value1> m<value1> Sets the Mode parameter [P050].

- <value1>:
 0 = Disabled
 1 = Prime (default)
 2 = Dispense
 3 = Meter
 4 = Agitate
 5 = Dispense MCV

q => READY/BUSY

q q<value1> Indicates Ready/Busy status.
 <value1> is 0 for Ready and not zero for Busy. Individual operational information can be determined using binary decoding as follows:

<u>bit</u>	<u>value</u>	<u>active if bit set</u>
0	1	Any Motion
1	2	Dispensing or Metering (including pre-op dwell, post-op dwell)
2	4	Priming or Agitating
3	8	Loading
4	16	Valving
5	32	Referencing
6	64	Drawback
7	128	Initializing, Not Configured, E-stop, IO Testing

q1 q1,<value2> Returns the present Fault Code parameter [P015].

r => DISPENSE RATE

r r<value1> Returns the present Dispense Rate parameter [P053] in increments per second.

r<value1> r<value1> Sets the Dispense Rate parameter [P053] in increments per second.

- Maximum: 150000
 Minimum: 1
 Default: 20000

s => STATUS INFORMATION

s s<value1> Returns the Volume Remaining parameter [P053].

s10 s10<value2> Returns the Pre-op Dwell parameter [P065] in centiseconds.

s10,<value2> s10,<value2> Sets the Pre-op Dwell parameter [P065] in centiseconds.

- <value2>
 Maximum: 60000 (600.00 seconds)
 Minimum: 0 (0 seconds)
 Default: 0 (0 seconds)

s11 s11,<value2> Returns the Valve Dwell parameter [P042] in centiseconds.

s11,<value2> s11,<value2> Sets the Valve Dwell parameter [P042] in centiseconds.

- <value2>
 Maximum: 255 (2.55 seconds)
 Minimum: 0 (0.00 seconds)
 Default: 20 (0.20 seconds)

s12 s12,<value2> Returns a bitmask of any warnings.

<value2> is 0 for no warnings:

<u>bit</u>	<u>value</u>	<u>warning condition if bit set</u>
0	1	Not used
1	2	Not used
2	4	Not used

3	8	Load is required
4	16	Reference is required
5	32	Not used
6	64	Not used
7	128	Not used
8	256	Not used
9	512	Mode is disabled or all pumps are disabled
10	1024	E-stop is active
11	2048	Not used
12	4096	Not used
13	8192	Not used
14	16384	Not used
15	32768	Not used

s13 s13,<value2> Returns a bitmask of the Logic Out signals.
 <value2>: is 0 for no Logic Out signals active.

<u>bit</u>	<u>value</u>	<u>Logic Out state if bit set</u>
0	1	Logic Out 1 active
1	2	Logic Out 2 active
2	4	Logic Out 3 active
3	8	Logic Out 4 active
4	16	Logic Out 5 active
5	32	Logic Out 6 active

s14 s14,<value2> Returns a bitmask of the HMI Lock Configuration parameter [P127].
 s14,<value2> s14,<value2> Sets a bitmask of the HMI Lock Configuration parameter [P127].
 <value2>: 0 is all unlocked (default):

<u>bit</u>	<u>value</u>	<u>Lock set if bit set</u>
0	1	Lock Most Values
1	2	Lock Pushbuttons
2	4	Lock Direction
3	8	Lock Mode

s15 s15,<value2> Returns the Post-op Dwell parameter [P066] in centiseconds.
 s15,<value2> s15,<value2> Sets the Post-op Dwell parameter [P066] in centiseconds.
 <value2>
 Maximum: 60000 (600.00 seconds)
 Minimum: 0 (0 seconds)
 Default: 0 (0 seconds)

s20 s20,<value2> Returns the present Running Torque parameter [P050] in percent.
 s20,<value2> s20,<value2> Sets the Running Torque parameter [P050] in percent.
 <value2>
 Maximum: 100 (100%)
 Minimum: 60 (60%)
 Default: 0 (100%)

s21 s21,<value2> Returns the present Reference Rate parameter [P043] in increments per second.
 s21,<value2> s21,<value2> Sets the Reference Rate parameter [P043] in increments per second.
 <value2>
 Maximum: 20000 (20,000 inc/s)
 Minimum: 500 (500 inc/s)
 Default: 20000 (20,000 inc/s)

s22 s22,<value2> Returns the present Actuator Number parameter [P020].
 s22,<value2> s22,<value2> Sets the Actuator Number parameter [P020].
 <value2>:
 0 = None (default)
 1 = SF8
 2 = SF10
 3 = SF12

4 = LF8
 5 = LF10
 6 = LF12

WARNING

It is necessary the Actuator Module attached to the Controller Module matches the actuator selected by the Actuator Number parameter. A mismatch of the Actuator Number parameter and the attached Actuator Module could result in both improper operation and overheating of the actuator. The selected Actuator Model Number part number MUST match the attached motor part number in both the base model number portion and any non “#” tabulation fields.

s1002 s1002,<value2> Returns the encoded valve fault identified. See the "k" command for encoding.

t => TIME LIMIT FOR PRIME

t t<value1> Returns present Prime Duration parameter [P087] in seconds.
 t<value1> t<value1> Sets the Prime Duration parameter [P087]. Small values of 't' will allow at least one pump cycle.
 <value1>
 Maximum: 60000 (60,000 seconds)
 Minimum: 1 (1 seconds)
 Default: 120 (120 seconds)

u => PRIME RATE

u u<value1> Returns the present Prime/Load Rate parameter [P082] in increments per second.
 u<value1> u<value1> Sets the Prime/Load Rate parameter [P082] in increments per second.
 <value1>
 Maximum: 150000 (150,000 inc/s)
 Minimum: 1 (1 inc/s)
 Default: 40000 (40,000 inc/s)

v => DISPENSE VOLUME

v v<value1> Returns the present Dispense Volume [P052] in increments.
 v<value1> v<value1> Sets the Dispense Volume [P052] in increments.. A volume of zero will not allow the unit to be triggered while in Dispense mode.
 <value1>
 Maximum: 40000 (40,000 inc)
 Minimum: 0 (0 inc)
 Default: 10000 (10,000 inc)

w => DRAWBACK

w1 w1,<value2> Returns the present Drawback Volume [P055] in increments.
 w1,<value2> w1,<value2> Sets the Drawback Volume [P055] in increments.
 <value2>
 Maximum: 40000 (40,000 inc)
 Minimum: 0 (0 inc)
 Default: 0 (0 inc)

w2 w2,<value2> Returns the present Drawback Rate parameter [P056] in increments per second.
 w2,<value2> w2,<value2> Sets the Drawback Rate [P056] parameter in increments per second.
 <value2>
 Maximum: 150000 (150,000 inc/s)
 Minimum: 1 (1 inc/s)
 Default: 40000 (40,000 inc/s)

w3 w3,<value2> Returns the present Drawback Dwell parameter [P057] in centiseconds.
 w3,<value2> w3,<value2> Sets the Drawback Dwell parameter [P057] in centiseconds.
 <value2>
 Maximum: 255 (2.55 seconds)
 Minimum: 0 (0.00 seconds)
 Default: 0 (0.00 seconds)

NOTE

The DISPENSE VOLUME setting PLUS the DRAWBACK ($v<value1> + w1,<value1>$) setting must be less than the maximum Volume of 40000.

x=> IVEK FACTORY AND TECH SERVICE

x1	x1<value2>	Returns the number of expected control cables.
x2	x2<value2>	Returns the installed pumps bitmask.
x3	x3	Initiates a reference operation that stops on the top linear sensor.
x30	x30<value2>	Returns the Serial Number parameter [P007].
x33	x33<value2>	Returns the Part Number parameter [P006].

y => AGITATE

y1	y1,<value2>	Returns the present Agitate Isolation Volume parameter [P086] in full pump strokes.
y1,<value2>	y1,<value2>	Sets the Agitate Isolation Volume parameter [P086] in full pump strokes. <value2> Maximum: 100 (100 strk) Minimum: 0 (0 strk) Default: 0 (0 strk)
y2	y2,<value2>	Returns the present Agitate Volume parameter [P082] in full pump strokes.
y2,<value2>	y2,<value2>	Sets the Agitate Volume parameter [P082] in full pump strokes. <value2> Maximum: 100 (100 strk) Minimum: 1 (1 strk) Default: 1 (1 strk)
y3	y3,<value2>	Returns the present Agitate Dwell parameter [P085] in centiseconds.
y3,<value2>	y3,<value2>	Sets the Agitate Dwell parameter [P085] in centiseconds. <value2> Maximum: 60000 (600.00 seconds) Minimum: 0 (0 seconds) Default: 0 (0 seconds)

z => SOFTWARE VERSION

z	z<value1>	Returns the software version. <value1> ASCII string similar to "560006-0101"
---	-----------	---

3.4.2.4 Warnings

Warnings indicate problems in the command received, or a state of the Controller Module which prohibits immediate operation. An asterisk (*) precedes warnings in responses. An appropriate command (other than 'clear faults') may be required to operate the pump.

- 1 Command Not Valid
Response to any unrecognized command.
- 2 Value Not Valid
Response to any out of range value.
- 3 Load Required
Pump is empty or remaining volume is less than the current dispense volume.
- 4 Reference Required
Pump needs to locate linear and rotary reference position. Reference cycle, using 'f' command, must be completed before continuing.
- 5 (not used)
Warning number reserved for consistency with functions of other controllers.
- 6 (not used)
Warning number reserved for consistency with functions of other controllers.
- 7 Controller Not Installed

- No response from controller with that address.
- 8 (not used)
Warning number reserved for consistency with functions of other controllers.
- 9 Controller/Pump Not Enabled
Specific controller or pump triggered with 'begin' or 'load' commands but all pumps disabled (k=0).
- 10 E-Stop, Guard
Emergency Stop or Guard switch (if installed).
- 11 (not used)
Warning number reserved for consistency with functions of other controllers.
- 15 (not used)
Warning number reserved for consistency with functions of other controllers.
- 16 (not used)
Warning number reserved for consistency with functions of other controllers.

3.4.2.5 Faults

Faults are a result of the system detecting improper operation of the Controller Module or Pump. All fault numbers will be greater than or equal to 999. An asterisk (*) precedes warnings in responses. The 'clear faults' command must be used before any subsequent operation of the affected controller is performed.

NOTE

After a fault is cleared, a reference MUST BE issued to ensure proper operation of the channel that was faulted.

Fault	Name	Description
0	No Faults	No faults are present in the Controller or Actuator
1000	Other Controller	Reserved
1001	Linear Sensor	The linear sensor was either not detected or detected at an unexpected location.
1002	Rotary Sensor	The rotary sensor was either not detected or detected at an unexpected location.
1003	Linear Stall	The motor driver is indicating a motor stall.
1004	Rotary Stall	The rotary sensors indicate a valve has stalled.
1005	Servo Drive	The servo drive is indicating a fault.
1010	Control Cable	A fault exists with one or both of the control cables (Cable A, Cable B)
1015	Motor Hardware	There is a fault with the servo drive or motor.
1016	Internal Software	An unexpected software path was encountered.

3.4.2.6 Typical Command Sequence

Following are typical command sequences for operating the system. Your sequence may vary depending on your application.

Prime Sequence

Typical sequence for Priming a system. Example is for a two-controller system. This procedure can also be used for cleaning and emptying the system of fluid.

	COMMAND	RESPONSE	OUTCOME
1.	1q<CR>	1q0*4<CR>	Query Actuator Ready/Busy. Actuators require reference (*4 warning)
2.	1f<CR>	1f*4<CR>	Initiate reference . Actuator reference required warning, *4, present until the Actuator references successfully.
3.	1q<CR>	1q0<CR>	Actuator ready, no warnings or faults.
4.	1d1<CR>	1d1<CR>	Sets the direction to forward.
5.	1m1<CR>	1m1<CR>	Sets to Prime Mode.
6.	1t120<CR>	1t1200<CR>	Sets the prime cycle to 120 seconds
7.	1u4000<CR>	1u4000<CR>	Sets Prime/Load rate to 4000 increments/sec. The Priming procedure fills the inlet tubing, pump head chamber, outlet tubing and nozzle with liquid.

8.	1k2241	1k2241<CR>	Enable controller 1, pump modules 1, 7,8 and 12 2241 decimal=100011000001 binary
9.	1b<CR>	1b<CR>	Begins Prime mode for controller 1, pump modules 1, 7, 8, and 12.
10.	1e<CR>	1e<CR>	Ends Prime mode (early if required) for controller number 1. The procedure is complete when there are no air bubbles remaining in the inlet tubing, pump head chamber, outlet tubing and nozzle. Prime the second controller in the same manner.

Dispense Sequence

Typical sequence for Dispensing. Example is for a two-controller system. The system must be Primed prior to dispensing.

	COMMAND	RESPONSE	OUTCOME
1.	1a1<CR>	1a1<CR>	Sets to load on empty.
2.	1d1<CR>	1d1<CR>	Sets the direction for forward.
3.	1k2730<CR>	1k2730<CR>	Enable controller 1, all even pump modules 2730 decimal = 101010101010 binary
4.	1k1365<CR>	1k1365<CR>	Enable controller 2, all odd pump modules 1365 decimal = 010101010101 binary
5.	1r60000<CR>	1r60000<CR>	Sets the Dispense / Meter Rate to 60,000 increments/sec.
6.	1v15000<CR>	1v15000<CR>	Sets the dispense volume for controller 1 to 15,000 increments.
7.	1v30000<CR>	1v30000<CR>	Sets the dispense volume for controller 1 to 30,000 increments.
8.	1m2<CR>	1m2<CR>	Sets controller 1 to Dispense mode. For initiation of a dispensing cycle, a 24V input trigger is necessary or receipt of the 'b' command.

Pump Reference Sequence

Typical sequence for referencing a system. A reference is required every time the unit is powered or after a system fault. The example is for a two-controller system.

	COMMAND	RESPONSE	OUTCOME
1.	1q<CR>	1q0*4<CR>	Query controller on power-up (or after fault clear).
2.	1f<CR>	1f*4<CR>	Start the reference sequence for controller number 1.
3.	1q<CR>	1q33*4<CR>	Controller is busy, reference in progress. The query can be repeated until the controller has completed the reference successfully. The reference sequence is processor time intensive. The repeated polling frequency should be as slow as the application allows and should not be less than the maximum response time.
4.	1q<CR>	1q0<CR>	The controller has completed the reference sequence successfully. The system is ready to use. An unsuccessful completion would result in a response of the form "1q0*<fault code>". This would require a clear error "1c" and the reference sequence to be retried. A second attempt resulting in a fault would require operator action to correct the fault condition.

Pump Fault Recovery Sequence

If, during the process of operation, the system encounters a fault it will report the fault in the response string. An example is given for a two-pump controller system with a fault on controller 1. The fault occurred while the pumps were dispensing.

	COMMAND	RESPONSE	OUTCOME
1.	1q<CR>	1q0*1001<CR>	Controller 1 has a linear sensor fault.
2.	1c<CR>	1c*1001<CR>	Clear the fault on controller 1.

3.	1q<CR>	1q0*4<CR>	Fault cleared, reference required.
4.	1f<CR>	1f*4<CR>	Start the reference sequence for controller number 1.
5.	1q<CR>	1q33*4<CR>	Controller is busy, reference in progress. The query can be repeated until the controller has completed the reference successfully. The reference sequence is processor time intensive. The repeated polling frequency should be as slow as the application allows and should not be less than the maximum response time.
6.	1q<CR>	1q0<CR>	The controller has completed the reference sequence successfully. The system is ready to use. An unsuccessful completion would result in a response of the form

3.5 INSTALLATION

General operating practices provide the best guidelines for locating the components of the system. The Controller Module should be located for ease of use during all phases of operation and maintenance.

3.6 OPTIONS

The Multiplex Version 3.0 Controller Module is available with either a Domestic or International power cord.

3.7 MAINTENANCE

No periodic maintenance is required on the Controller Module, beyond standard practices for electronic equipment.

3.8 PROBLEM GUIDE

Table 3.4 contains a list of possible problems, causes and solutions for the Controller Module.

3.9 SPECIFICATIONS

The Logic I/O is intended to be connected directly to a customer's PLC, if present. The connections provided allow the customer to wire the inputs and outputs as sinking or sourcing depending on the PLC configuration.

INPUT POWER

Voltage: 100 – 240 VAC, 50/60 Hz
Maximum Current: 4 A

E-STOP

Nominal Voltage: 24 VDC
Maximum Voltage: 30 VDC
Active Threshold: > 15 VDC
Inactive Threshold: < 5 VDC
Nominal Current: 30 mA

LOGIC IN

Nominal voltage: 24 VDC
Maximum voltage: 28.8 VDC
Active Threshold: > 15 VDC
Inactive Threshold: < 5 VDC
Nominal Current: 4 mA
Isolation Voltage: 500 Veff

LOGIC OUT

Switched Voltage: 5 – 48 VDC
Switched Current: 0.1 mA – 500 mA
Leakage Current (off): 10 µA

3.10 MODEL NUMBER

The model number provides important information about the specifics of your Motor Module. Refer to this number when calling IVEK Technical support. The model number for your Controller Module is documented in the Title Page section of this manual.

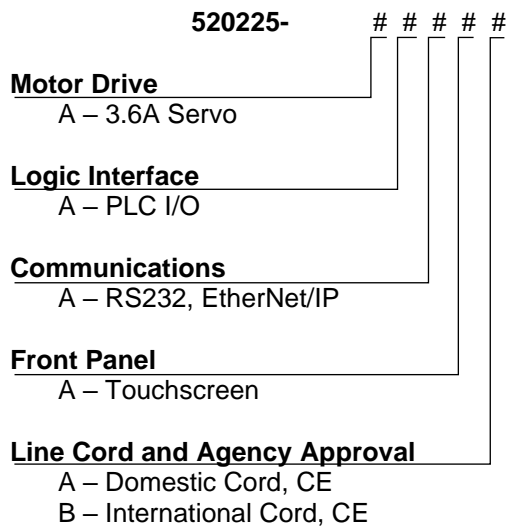

3.11 ILLUSTRATED PARTS BREAKDOWN

There are no replaceable parts on the Controller Module.

Table 3.4 Common Operational Problems And Solutions

PROBLEM	PROBABLE CAUSE	POSSIBLE SOLUTION
No power, nothing works.	AC power may be absent or inadequate. Or unit not plugged in	Ensure AC power cord is plugged into a properly grounded three-prong outlet capable of supplying the voltage listed in the Title Page section of this manual.
	Fuse is blown.	Unplug main power cord from outlet. Remove fuse from rear panel fuse holder. Test fuse conductivity. Install good fuse in rear panel fuse holder.
Power is on, Controller Module accepts trigger, piston fails to move and Actuator Module makes a sound. This condition does not harm the system.	A Pump Module or motor malfunction can cause this problem.	Turn off Controller Module power. Remove Pump Module from Actuator Module. Turn on Controller Module and try again.
		If the motor operates correctly, the pump may need to be cleaned or serviced.
Power is on, Controller Module accepts a trigger, (ACTIVE indicator illuminates), piston fails to move, and Actuator Module is silent.	Channel fuse is blown.	Unplug main power cord from outlet. Remove fuse from fuse holder. Test fuse conductivity. Replace if necessary.
	A motor malfunction can cause this problem.	Turn off Controller Module power. Check to ensure Actuator Module is properly connected to Controller Module. Turn on Controller Module and try again. If the motor operates incorrectly servicing may be necessary to the motor or the controller. Return complete Controller, Actuator and Pump Modules to IVEK Corporation for repair.
Controller Module power on and operational, but will not activate Actuator.	I/O Cable	Check connection of cable between Controller Module and Actuator Module. Inspect and repair faulty cable.
	Channels not referenced	Go to Fault screen and reference all channels.
	E-Stop active or no E-Stop connected.	Reset E-Stop switch and/or connect E-Stop cable.
	No air supply.	Verify air supply is connected and is pressurized.
Controller Module has power, touchscreen does not.	Faulty Touchscreen.	Turn Controller Module power off then back on.
A communication error occurs on one or more channels.	Faulty Touchscreen.	Turn Controller Module power off then back on.
After pressing a button, expected results do not occur.	Channels not referenced.	Go to Fault screen and press the "REF ALL" button to reference all channels.
	Slow response time.	Wait longer before pressing another button.
The Ready/Busy display is not as expected.	Slow response time.	Wait longer before pressing another button.
If none of the above solves the problem, contact IVEK technical support for assistance.		

Appendix A

Appendix A list all the parameters associated with the Multiplex Version 3.0 Controller Module. Please note the data types are generally understood, though some Rockwell PLCs do not support the given data types. In those cases, use the following mappings:

Parameters Class (0x0f)				
Instance 0 (Class) Services Supported				
ID	Name			
14	Get_Attribute_Single			
Instance 0 (Class) Attributes				
ID	Name	Data Type	Data Size	Value
1	Revision	UINT	2	0
2	Max instance	UINT	2	229
3	Number of instances	UINT	2	229
4	Optional instance attributes	UINT, UINT[]	2+2*N	0, []
5	Optional services	UINT, UINT[]	2+2*N	1, [0x4b]
6	Max class attribute	UINT	2	9
7	Max instance attribute	UINT	2	21
8	Descriptor	WORD	2	0x000b
9	Configuration assembly instance	UINT	2	0
Instance 1-229 Services Supported				
ID	Name			
1	Get_Attributes_All			
14	Get_Attribute_Single			
16	Set_Attribute_Single			
75	Get_Enum_String			
Instance 1-229 Attributes				

ID	Name	Data Type	Data Size	Access	Value				
1	Value	Varies	Varies	Varies	Current value of the parameter				
2	Link path size	USINT	1	Get	0				
3	Link path	Empty	0	Get	Empty				
4	Descriptor	WORD	2	Get	Bitmask of parameter flags: Bitwise OR of: 0x10: Readonly, parameter value cannot be set 0x20: Monitor, parameter data is updated in real-time by the unit 0x100: Hidden, parameter should not be displayed				
5	Data type	USINT	1	Get	Specifies data type used in many other attributes using codes from CIP standard, Vol. 1, table C-2.1.				
6	Data size	USINT	1	Get	Size in bytes of data type				
7	Parameter name string	SHORT_STRING	Varies	Get	Text string for parameter name				
8	Unit string	SHORT_STRING	Varies	Get	Text string for parameter base units				
9	Help string	SHORT_STRING	Varies	Get	Text string for description of parameter				
10	Minimum value	Varies	Varies	Get	Minimum value of parameter				
11	Maximum value	Varies	Varies	Get	Maximum value of parameter				
12	Default value	Varies	Varies	Get	Default value of parameter				
13	Scaling multiplier	UINT	2	Get	0 (disabled)				
14	Scaling divisor	UINT	2	Get	0 (disabled)				
15	Scaling base	UINT	2	Get	0 (disabled)				
16	Scaling offset	INT	2	Get	0 (disabled)				
17	Multiplier link	UINT	2	Get	0 (disabled)				
18	Divisor link	UINT	2	Get	0 (disabled)				
19	Base link	UINT	2	Get	0 (disabled)				
20	Offset link	UINT	2	Get	0 (disabled)				
21	Decimal precision	USINT	1	Get	Implied decimal places in value (e.g. with precision=3, a raw value of 1000 means an effective value of 1.000)				
Parameter Instances									
ID	Name	Data Type	Data Size	Access	Value	Effective Unit	Minimum	Maximum	Default

1	ProductID	DINT	4	Get	Product identifier number Constant value: 2		2	2	2
2	ADIMajorVersion	INT	2	Get	Parameter map major version number Constant value: 1		1	1	1
3	ADIMinorVersion	INT	2	Get	Parameter map minor version number Constant value: 1		2	2	2
4	FirmwareVersion	SHORT_ STRING	varies	Get	Firmware version text "560006-0102" or similar		n/a	n/a	n/a
6	PartNumber	SINT	1	Get	IVEK controller part number One of: 1: 520225-AAAAA 2: 520225-AAAAB 3: Custom		0	3	0
7	SerialNumber	DINT	4	Get	IVEK controller serial number Unique per controller		0	21474836 47	0
10	Commands	DWORD	4	Get/Set	Contains commands to control the unit. Commands are executed only when a new value is set which changes the bit from 0 to 1; they must be reset to 0 to issue the command again. Bitwise OR of: Bit 1 (2): End Bit 2 (4): Begin production Bit 3 (8): Begin fluidic Bit 4 (16): Reference Bit 5 (32): Clear fault Bit 7 (128): Load Bit 13 (8192): Clear required		0	42949672 95	0

12	Status	DWORD	4	Get	Flags indicating operational status Bitwise OR of: Bit 0 (1): Initialized Bit 1 (2): Configured Bit 2 (4): Faulted Bit 4 (16): Motion disabled Bit 5 (32): Ref required Bit 6 (64): Load required Bit 8 (256): Ready idle Bit 9 (512): Ready production Bit 10 (1024): Ready fluidic Bit 11 (2048): Ready reference Bit 12 (4096): Ready load Bit 15 (32768): Op required Bit 16 (65536): Busy Bit 17 (131072): Busy production Bit 18 (262144): Busy fluidic Bit 19 (524288): Busy reference Bit 20 (1048576): Busy load Bit 21 (2097152): Busy port Bit 25 (33554432): Chamber full Bit 26 (67108864): Success pulse Bit 27 (134217728): Success last	0	4294967295	0
----	--------	-------	---	-----	---	---	------------	---

13	StatusExt	DWORD	4	Get	Extended status flags Bitwise OR of: Bit 0 (1): Dwelling Bit 1 (2): Discharging Bit 2 (4): Intaking Bit 3 (8): Piston moving Bit 4 (16): Intake valving Bit 5 (32): Drawback dwell Bit 6 (64): Drawback Bit 9 (512): Agitate dwell Bit 16 (65536): Port 1 fault Bit 17 (131072): Port 2 fault Bit 18 (262144): Port 3 fault Bit 19 (524288): Port 4 fault Bit 20 (1048576): Port 5 fault Bit 21 (2097152): Port 6 fault Bit 22 (4194304): Port 7 fault Bit 23 (8388608): Port 8 fault Bit 24 (16777216): Port 9 fault Bit 25 (33554432): Port 10 fault Bit 26 (67108864): Port 11 fault Bit 27 (134217728): Port 12 fault Bit 28 (268435456): Port 13 fault Bit 29 (536870912): Port 14 fault Bit 30 (1073741824): Port 15 fault Bit 31 (2147483648): Port 16 fault	0	4294967295	0
----	-----------	-------	---	-----	--	---	------------	---

14	State	INT	2	Get	Status identifier number One of: 0: Idle 1: Priming 2: Dispensing 3: Metering 4: Drawback dwell 5: Drawback 6: Faulted 7: Referencing 8: Initializing 9: Pre operation dwell 10: Post operation dwell 11: Auto idle 12: Isolating 13: Agitating 14: Returning 15: Bubble clear 16: Loading 17: Changing port 18: Agitate dwell 19: Parking port 20: Parked port 21: Unparking port 22: Motion locked 23: Not configured 24: Feeding 25: Feed wait 26: Fault clear 27: Intaking 28: Jogging	0	28	0
15	FaultCode	DINT	4	Get	Fault identifier number	0	61016	0

20	ActuatorNum	INT	2	Get/Set	Type of connected actuator One of: 0: None 1: SF8 2: SF10 3: SF12 4: LF8 5: LF10 6: LF12		0	6	0
24	PumpChamberVol	DINT	4	Get	Chamber volume of the attached pump Constant value: 40000	increments	40000	40000	40000
25	PumpResolution	DINT	4	Get	Volume resolution of the attached pump Constant value: 1	increments	1	1	1
26	PumpRateRes	DINT	4	Get	Volume rate resolution of the attached pump Constant value: 1	increments/s econd	1	1	1
31	RunningTorque	SINT	1	Get/Set	The amount of the motor's maximum torque to apply	percent	60	100	100
42	ValveDwell	INT	2	Get/Set	Time to dwell before sensing valve motion	centiseconds	0	255	20
43	ReferenceRate	DINT	4	Get/Set	Rate of movement while referencing	increments/s econd	500	20000	20000

44	PumpsEnabled	WORD	2	Get/Set	Bitmask of enabled pumps Bitwise OR of: Bit 0 (1): Pump 1 enabled Bit 1 (2): Pump 2 enabled Bit 2 (4): Pump 3 enabled Bit 3 (8): Pump 4 enabled Bit 4 (16): Pump 5 enabled Bit 5 (32): Pump 6 enabled Bit 6 (64): Pump 7 enabled Bit 7 (128): Pump 8 enabled Bit 8 (256): Pump 9 enabled Bit 9 (512): Pump 10 enabled Bit 10 (1024): Pump 11 enabled Bit 11 (2048): Pump 12 enabled Bit 12 (4096): Pump 13 enabled Bit 13 (8192): Pump 14 enabled Bit 14 (16384): Pump 15 enabled Bit 15 (32768): Pump 16 enabled	0	65535	0
----	--------------	------	---	---------	--	---	-------	---

45	PumpsInstalled	WORD	2	Get	Bitmask of installed pumps Bitwise OR of: Bit 0 (1): Pump 1 present Bit 1 (2): Pump 2 present Bit 2 (4): Pump 3 present Bit 3 (8): Pump 4 present Bit 4 (16): Pump 5 present Bit 5 (32): Pump 6 present Bit 6 (64): Pump 7 present Bit 7 (128): Pump 8 present Bit 8 (256): Pump 9 present Bit 9 (512): Pump 10 present Bit 10 (1024): Pump 11 present Bit 11 (2048): Pump 12 present Bit 12 (4096): Pump 13 present Bit 13 (8192): Pump 14 present Bit 14 (16384): Pump 15 present Bit 15 (32768): Pump 16 present	0	65535	0
50	ProductionMode	SINT	1	Get/Set	The operating mode during production operations One of: 0: Disabled 1: Prime 2: Dispense 3: Meter 4: Agitate 5: MCV	0	5	1
51	ProdDirection	SINT	1	Get/Set	Direction to move fluid during production operations One of: 0: Reverse 1: Forward	0	1	1

52	DispenseVolume	DINT	4	Get/Set	Volume to discharge during production operations	increments	0	40000	10000
53	MaxDischargeRate	DINT	4	Get/Set	Rate the pump discharges during a Dispense or Meter operation	increments/second	1	150000	20000
55	DrawbackVolume	DINT	4	Get/Set	Volume to drawback during production operations	increments	0	40000	0
56	DrawbackRate	DINT	4	Get/Set	Rate at which the pump drawbacks during drawback operations	increments/second	1	150000	20000
57	DrawbackDwell	INT	2	Get/Set	Time to dwell between discharge and drawback	centiseconds	0	255	0
58	LinLoadMode	SINT	1	Get/Set	Automatic reload mode One of: 0: Manual 1: Empty 2: Every		0	2	0
65	PreOpDwell	DINT	4	Get/Set	Time to dwell after starting an operation before discharging	centiseconds	0	60000	0
66	PostOpDwell	DINT	4	Get/Set	Time to dwell after completing an operation	centiseconds	0	60000	0
82	AgitateVolume	DINT	4	Get/Set	Volume to displace during each cycle of an Agitate operation	strokes	1	100	1
83	PrimeRate	DINT	4	Get/Set	Rate at which to discharge during a Prime operation	increments/second	1	150000	40000
85	AgitateDwell	DINT	4	Get/Set	Time to wait between each reverse and forward cycle	centiseconds	0	60000	0
86	AgitateIsoVolume	DINT	4	Get/Set	Isolation volume of the Agitate operation	strokes	0	100	0
87	PrimeDuration	DINT	4	Get/Set	Time to run a Prime operation	seconds	1	60000	20
90	TotalVolume	DINT	4	Get/Set	Total production volume since last power cycle	increments	0	200000000	0
92	VolumePosition	DINT	4	Get	Position of the pump	increments	0	40000	0
93	VolumeRemaining	DINT	4	Get	Remaining chamber volume	increments	0	40000	0
95	TotalCycles	DINT	4	Get/Set	Total production cycles		0	200000000	0

127	HmiLockConfig	BYTE	1	Get/Set	Prevent settings from being changed using the touchscreen Bitwise OR of: Bit 0 (1): Lock most values Bit 1 (2): Lock pushbuttons Bit 2 (4): Lock direction Bit 3 (8): Lock mode	0	255	0
138	EraseParams	BOOL	1	Get/Set	If set to TRUE, resets unit to factory default values	FALSE	TRUE	FALSE
160	LogicIn1Config	USINT	1	Get/Set	Configure the function of input 1 One of: 0: Disabled 2: Trigger stop 3: Trigger production 4: Trigger fluidic 5: Trigger reference 6: Trigger clear fault 8: Trigger load 14: Trigger clear required 15: Gate production 16: Gate fluidic 17: Lock HMI	0	17	3
161	LogicIn2Config	USINT	1	Get/Set	Configure the function of input 2 One of: 0: Disabled 2: Trigger stop 3: Trigger production 4: Trigger fluidic 5: Trigger reference 6: Trigger clear fault 8: Trigger load 14: Trigger clear required 15: Gate production 16: Gate fluidic 17: Lock HMI	0	17	8

162	LogicIn3Config	USINT	1	Get/Set	Configure the function of input 3 One of: 0: Disabled 2: Trigger stop 3: Trigger production 4: Trigger fluidic 5: Trigger reference 6: Trigger clear fault 8: Trigger load 14: Trigger clear required 15: Gate production 16: Gate fluidic 17: Lock HMI	0	17	0
163	LogicIn4Config	USINT	1	Get/Set	Configure the function of input 4 One of: 0: Disabled 2: Trigger stop 3: Trigger production 4: Trigger fluidic 5: Trigger reference 6: Trigger clear fault 8: Trigger load 14: Trigger clear required 15: Gate production 16: Gate fluidic 17: Lock HMI	0	17	0

164	LogicIn5Config	USINT	1	Get/Set	Configure the function of input 5 One of: 0: Disabled 2: Trigger stop 3: Trigger production 4: Trigger fluidic 5: Trigger reference 6: Trigger clear fault 8: Trigger load 14: Trigger clear required 15: Gate production 16: Gate fluidic 17: Lock HMI		0	17	0
172	LogicIn1Invert	BOOL	1	Get/Set	Invert input 1 if set to TRUE		FALSE	TRUE	FALSE
173	LogicIn2Invert	BOOL	1	Get/Set	Invert input 2 if set to TRUE		FALSE	TRUE	FALSE
174	LogicIn3Invert	BOOL	1	Get/Set	Invert input 3 if set to TRUE		FALSE	TRUE	FALSE
175	LogicIn4Invert	BOOL	1	Get/Set	Invert input 4 if set to TRUE		FALSE	TRUE	FALSE
176	LogicIn5Invert	BOOL	1	Get/Set	Invert input 5 if set to TRUE		FALSE	TRUE	FALSE
184	LogicIn1Value	BOOL	1	Get	Present value of Logic Input 1		FALSE	TRUE	FALSE
185	LogicIn2Value	BOOL	1	Get	Present value of Logic Input 2		FALSE	TRUE	FALSE
186	LogicIn3Value	BOOL	1	Get	Present value of Logic Input 3		FALSE	TRUE	FALSE
187	LogicIn4Value	BOOL	1	Get	Present value of Logic Input 4		FALSE	TRUE	FALSE
188	LogicIn5Value	BOOL	1	Get	Present value of Logic Input 5		FALSE	TRUE	FALSE
197	StartIoTest	BOOL	1	Get/Set	If set to TRUE, requests I/O test mode		FALSE	TRUE	FALSE

200	LogicOut1Config	USINT	1	Get/Set	Configure the function of output 1 One of: 0: Disabled 1: Ready init 2: Ready config 3: Status fault 5: Status motion disabled 6: Status reference required 7: Status load required 8: Status port required 9: Ready idle 10: Ready production 11: Ready fluidic 12: Ready reference 13: Ready load 16: Status operation required 17: Busy operating 18: Busy production ops 19: Busy fluidic ops 20: Busy reference operation 21: Busy load operation 22: Busy port operation 26: Status full 27: Success pulse 28: Success last 29: Busy dwell 30: Busy discharge 31: Busy intake 32: Busy intake piston 33: Busy valve 34: Busy drawback dwell 35: Busy drawback 36: Agitate dwell actuating	0	36	9
-----	-----------------	-------	---	---------	---	---	----	---

201	LogicOut2Config	USINT	1	Get/Set	Configure the function of output 2 One of: 0: Disabled 1: Ready init 2: Ready config 3: Status fault 5: Status motion disabled 6: Status reference required 7: Status load required 8: Status port required 9: Ready idle 10: Ready production 11: Ready fluidic 12: Ready reference 13: Ready load 16: Status operation required 17: Busy operating 18: Busy production ops 19: Busy fluidic ops 20: Busy reference operation 21: Busy load operation 22: Busy port operation 26: Status full 27: Success pulse 28: Success last 29: Busy dwell 30: Busy discharge 31: Busy intake 32: Busy intake piston 33: Busy valve 34: Busy drawback dwell 35: Busy drawback 36: Agitate dwell actuating	0	36	3
-----	-----------------	-------	---	---------	---	---	----	---

202	LogicOut3Config	USINT	1	Get/Set	Configure the function of output 3 One of: 0: Disabled 1: Ready init 2: Ready config 3: Status fault 5: Status motion disabled 6: Status reference required 7: Status load required 8: Status port required 9: Ready idle 10: Ready production 11: Ready fluidic 12: Ready reference 13: Ready load 16: Status operation required 17: Busy operating 18: Busy production ops 19: Busy fluidic ops 20: Busy reference operation 21: Busy load operation 22: Busy port operation 26: Status full 27: Success pulse 28: Success last 29: Busy dwell 30: Busy discharge 31: Busy intake 32: Busy intake piston 33: Busy valve 34: Busy drawback dwell 35: Busy drawback 36: Agitate dwell actuating	0	36	7
-----	-----------------	-------	---	---------	---	---	----	---

203	LogicOut4Config	USINT	1	Get/Set	Configure the function of output 4 One of: 0: Disabled 1: Ready init 2: Ready config 3: Status fault 5: Status motion disabled 6: Status reference required 7: Status load required 8: Status port required 9: Ready idle 10: Ready production 11: Ready fluidic 12: Ready reference 13: Ready load 16: Status operation required 17: Busy operating 18: Busy production ops 19: Busy fluidic ops 20: Busy reference operation 21: Busy load operation 22: Busy port operation 26: Status full 27: Success pulse 28: Success last 29: Busy dwell 30: Busy discharge 31: Busy intake 32: Busy intake piston 33: Busy valve 34: Busy drawback dwell 35: Busy drawback 36: Agitate dwell actuating	0	36	0
-----	-----------------	-------	---	---------	---	---	----	---

204	LogicOut5Config	USINT	1	Get/Set	Configure the function of output 5 One of: 0: Disabled 1: Ready init 2: Ready config 3: Status fault 5: Status motion disabled 6: Status reference required 7: Status load required 8: Status port required 9: Ready idle 10: Ready production 11: Ready fluidic 12: Ready reference 13: Ready load 16: Status operation required 17: Busy operating 18: Busy production ops 19: Busy fluidic ops 20: Busy reference operation 21: Busy load operation 22: Busy port operation 26: Status full 27: Success pulse 28: Success last 29: Busy dwell 30: Busy discharge 31: Busy intake 32: Busy intake piston 33: Busy valve 34: Busy drawback dwell 35: Busy drawback 36: Agitate dwell actuating	0	36	0
-----	-----------------	-------	---	---------	---	---	----	---

205	LogicOut6Config	USINT	1	Get/Set	Configure the function of output 6 One of: 0: Disabled 1: Ready init 2: Ready config 3: Status fault 5: Status motion disabled 6: Status reference required 7: Status load required 8: Status port required 9: Ready idle 10: Ready production 11: Ready fluidic 12: Ready reference 13: Ready load 16: Status operation required 17: Busy operating 18: Busy production ops 19: Busy fluidic ops 20: Busy reference operation 21: Busy load operation 22: Busy port operation 26: Status full 27: Success pulse 28: Success last 29: Busy dwell 30: Busy discharge 31: Busy intake 32: Busy intake piston 33: Busy valve 34: Busy drawback dwell 35: Busy drawback 36: Agitate dwell actuating	0	36	0
212	LogicOut1Invert	BOOL	1	Get/Set	If set to TRUE, inverts output 1	FALSE	TRUE	FALSE
213	LogicOut2Invert	BOOL	1	Get/Set	If set to TRUE, inverts output 2	FALSE	TRUE	TRUE
214	LogicOut3Invert	BOOL	1	Get/Set	If set to TRUE, inverts output 3	FALSE	TRUE	FALSE
215	LogicOut4Invert	BOOL	1	Get/Set	If set to TRUE, inverts output 4	FALSE	TRUE	FALSE

216	LogicOut5Invert	BOOL	1	Get/Set	If set to TRUE, inverts output 5		FALSE	TRUE	FALSE
217	LogicOut6Invert	BOOL	1	Get/Set	If set to TRUE, inverts output 6		FALSE	TRUE	FALSE
224	LogicOut1Value	BOOL	1	Get/Set	Value to force Logic Output 1 when in I/O Test mode.		FALSE	TRUE	FALSE
225	LogicOut2Value	BOOL	1	Get/Set	Value to force Logic Output 2 when in I/O Test mode.		FALSE	TRUE	FALSE
226	LogicOut3Value	BOOL	1	Get/Set	Value to force Logic Output 3 when in I/O Test mode.		FALSE	TRUE	FALSE
227	LogicOut4Value	BOOL	1	Get/Set	Value to force Logic Output 4 when in I/O Test mode.		FALSE	TRUE	FALSE
228	LogicOut5Value	BOOL	1	Get/Set	Value to force Logic Output 5 when in I/O Test mode.		FALSE	TRUE	FALSE
229	LogicOut6Value	BOOL	1	Get/Set	Value to force Logic Output 6 when in I/O Test mode.		FALSE	TRUE	FALSE

Instance 100 & 101 Services Supported							
ID	Name						
14	Get_Attribute_Single						
16	Set_Attribute_Single						
Instance 100 & 101 Attributes							
ID	Name	Data Type	Data Size	Access	Value		
3	Data	BYTE[]	Varies	Varies	Current assembly data		
4	Size	UINT	2	Get	Number of bytes in data		
Assembly Instances							
ID	Name	Data Type	Data Size	Access	Bytes	Data Type	Value
100	ProducingData	BYTE[8]	8	Get/Set	0-3	DWORD	Commands per Parameter 10
					4-5	WORD	Pumps Enabled per Parameter 44
					6-7	WORD	Additional flags: Bitwise OR of: 32768: Apply Pumps Enabled value
101	ConsumingData	BYTE[20]	20	Get	0-3	DWORD	Status per Parameter 12
					4-7	DWORD	StatusExt per Parameter 13
					8-9	UINT	Position per Parameter 92
					10-11	WORD	Reserved
					12-15	DINT	Total Volume per Parameter 90
					16-19	DINT	Cycle Count per Parameter 95

Identity Class (0x01)				
Instance 0 (Class) Services Supported				
ID	Name			
14	Get_Attribute_Single			
Instance 0 (Class) Attributes				
ID	Name	Data Type	Data Size	Value
1	Revision	UINT	2	1
2	Max instance	UINT	2	1
6	Max class attribute	UINT	2	7
7	Max instance attribute	UINT	2	9
Instance 1 Services Supported				
ID	Name			
14	Get_Attribute_Single			
Instance 1 Attributes				
ID	Name	Data Type	Data Size	Value
1	Vendor ID	UINT	2	887
2	Device type	UINT	2	12
3	Product code	UINT	2	42780
4	Revision	USINT[2]	4	1, 35
5	Status	WORD	2	0x30
6	Serial number	UDINT	4	Unique per controller
7	Product name	SHORT_STRING	varies	"X20IF10D3-1"
8	State	USINT	1	3
9	Configuration consistency value	UINT	2	0