

---

## Table of Contents

---

Section	Description	Page #
<b>5.</b>	<b>Single Ended MegaSpense Motor/Base Module.....</b>	<b>5.2</b>
5.1	Description.....	5-2
5.2	Operation.....	5-2
5.2.1	Thumbwheel .....	5-2
5.2.2	Spindle Sensor.....	5-2
5.2.3	Spindle.....	5-3
5.3	Installation .....	5-3
5.4	Options.....	5-3
5.5	Maintenance .....	5-4
5.6	Problem Guide.....	5-4
5.7	Specifications.....	5-5
5.8	Model Number .....	5-5
5.9	Illustrated Parts Breakdown.....	5-5

## 5. SINGLE ENDED MEGASPENSE MOTOR/BASE MODULE

### 5.1 DESCRIPTION (Figure 5.1)

The Single Ended MegaSpense Motor/Base Module, hereafter referred to as the Motor/Base Module, is comprised of the motor to drive the Pump Module, the base to support the Pump Module, the displacement adjustment mechanism and the cable connector. The motor provides accurate control. The displacement adjustment mechanism changes the angle between the axis of the motor and the axis of the Pump Module thus changing the pumped volume. The cable connector provides a connection point for the cable from the Controller Module.

#### WARNING

*Never remove a safety cover while the motor is running. Moving parts are located under these covers. Physical harm to individuals is possible.*

The Standard Motor/Base Module measures 212.3mm (8.36") wide, 444mm (17.48") long and 206.4mm (8.13") high with feet and weighs approximately 10 kilograms (22 Pounds). Dimensions listed are with no options.

### 5.2 OPERATION

The Motor/Base Module includes a thumbwheel for adjusting the calibration of the pump, a spindle rotation sensor and a drive spindle to move the piston.

#### 5.2.1 Thumbwheel

The thumbwheel is used to change the angular relationship of the Pump Module axis to the drive spindle axis. The greater the angle, the greater the volume of liquid dispensed for each revolution. A vernier scale is located on the Motor/Base Module to provide a reference setting. The reference lines are in 1° increments to provide a range of 0° (minimum output) to 15° (maximum output). The thumbwheel contains 3.9mm (0.156") holes for inserting a rod for fine adjustments.

#### 5.2.2 Spindle Sensor

A sensor detects the rotation of the spindle, and is used to count revolutions, stop the pump during the intake stroke and detect stalls.

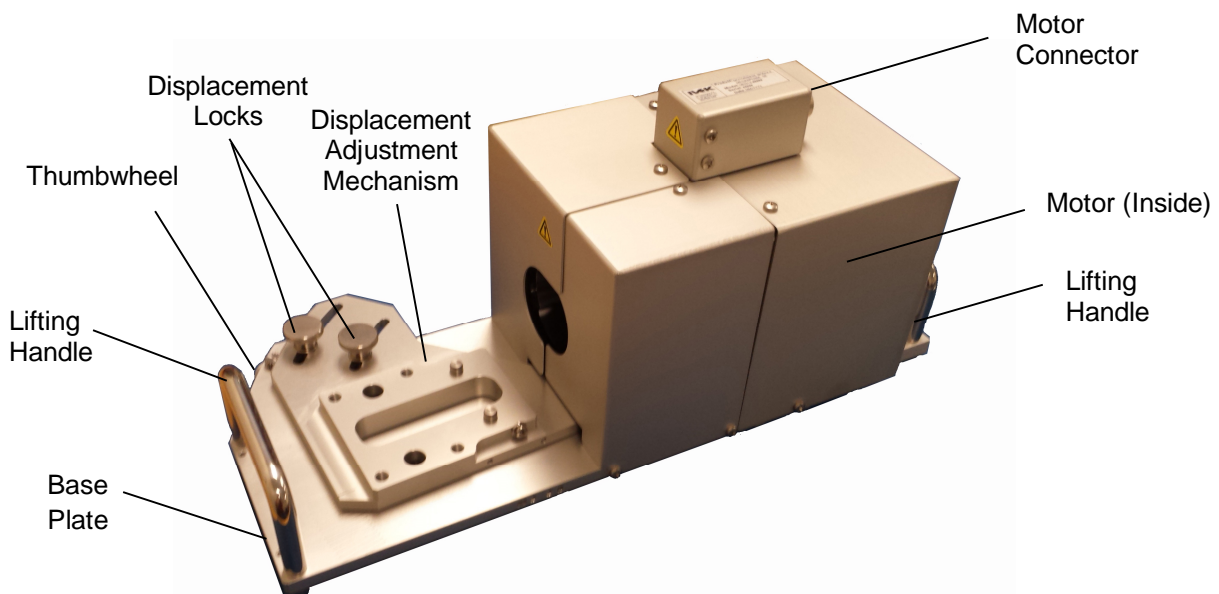

Figure 5.1 Single Ended MegaSpense Motor/Base Module

### 5.2.2.1 Volume Strokes

The spindle sensor allows the Controller Module to count the revolutions of the spindle to ensure the requested number of revolutions (volume strokes) has been completed. Just prior to reaching the required count, the sensor signals the stepper motor drive circuitry to decelerate.

### 5.2.2.2 Stopped Location

The Controller Module decelerates the motor and stops the piston during the intake stroke of the pump. The sensor signals the stepper motor drive circuitry to decelerate, thereby insuring the position at the end of the dispense is based on a sensed position, and not on the accumulation of motion commands to the motor drive circuitry.

If the piston is at a random position, such as after reassembly due to cleaning, the piston will be properly indexed to stop during the intake stroke following the completion of the first dispense cycle (with no faults). By stopping during the intake stroke, variations in the exact stopping position will not affect dispense accuracy.

### 5.2.2.3 Stall Detect

Motor stalls are detected if a signal from the spindle sensor is not detected for each revolution commanded to the motor. In a stepping motor system, a stall has occurred if more than the 200 required steps for a revolution have been commanded without a subsequent signal from the spindle sensor. A small margin above 200 steps is allowed to prevent minor variations from incorrectly signaling a fault. If an error is detected, the system can be designed to either inhibit further dispensing, alert the operator or provide a reject signal for integrated process control. (Refer to Chapter 3 for more information)

## 5.2.3 Spindle

A spindle, containing a spherical bearing, is mounted on the motor shaft. When the Pump Module is mounted with its drive pin inserted into the spherical bearing, the spindle drives the piston in a motion that combines rotation and reciprocation.

When the Pump Module is mounted on the Motor/Base Module, the pin extends through the center bore of the spherical bearing. At zero pump displacement, the axis of the piston aligns with the axis of the spindle and motor shaft. As the motor turns, the spindle drives the piston in a purely rotational motion. Introducing an angle between the axis of the spindle and the axis of the piston adds a reciprocating motion to the rotation of the piston. The magnitude of the reciprocating motion is a function (sinusoidal) of the angle between the axis of the piston and the axis of the spindle.

## 5.3 INSTALLATION

Plan the installation so the intake and discharge tubing and the end cap which holds the Pump Module's cylinder in place can be easily accessed. Additional consideration should be taken regarding the fluid flow. Always keep the discharge of the Pump Module even with or higher than the intake and never mount the Motor/Base Module so the Pump Module's cylinder end cap faces upward. Figure 5.2 shows the four mounting hole locations.

Some Motor/Base Modules are designed to work with certain Controller Modules. Make sure the Motor/Base Module is used with the Controller Module with which it was shipped. Please contact IVEK Corporation if there are any questions.

Refer to the MegaSpense Pump Module chapter 7 for installing the Pump Module onto the Motor/Base Module.

## 5.4 OPTIONS

There are currently no options available for this Motor/Base Module.

## 5.5 MAINTENANCE

**CAUTION**

*Never connect or disconnect the cable from the Motor/Base Module connector while power is on. Damage to the equipment may result.*

Minimal maintenance is necessary for this Motor/Base Module.

**5.6 PROBLEM GUIDE**

Table 5.1 contains a list of possible problems, causes and solutions for the Motor/Base Module.

**Table 5.1 Common Operational Problems and Solutions**

<b>PROBLEM</b>	<b>PROBABLE CAUSE</b>	<b>POSSIBLE SOLUTION</b>
Power is on, Controller Module accepts trigger, motor spindle fails to rotate and motor makes a sound that fluctuates in tone. * This condition does not harm the system.	Rotational binding is present.	Turn off controller power. Remove spindle guard and turn the spindle. If the spindle does not turn the Pump Module may need cleaning. If the spindle turns contact IVEK technical support for assistance.
Power is on, Controller Module accepts a trigger, (START indicator illuminates, STOP indicator does not), motor spindle fails to rotate, and motor is silent.	A motor malfunction can cause this problem.	Turn off Controller Module power. Check to ensure Motor/Base Module is properly connected to Controller Module. Turn on Controller Module and try again. If the motor operates incorrectly, servicing may be necessary to the motor or the controller. Return complete Controller, Motor/Base and Pump Modules to IVEK Corporation for repair.
Controller Module power on and operational, but will not actuate Motor/Base Module.	Controller cable	Check connection of cable between Controller Module and Motor/Base Module. Inspect and replace faulty cable.
Motor turns 3 times, stalls and repeats.	Sensor problem	Contact IVEK technical support for assistance.
Thumb wheel does not operate smoothly.	Dirt in gear tooth	Clean.
Low volume noise during operation.	Sensor End Shield vibrating.	Tighten end shield.

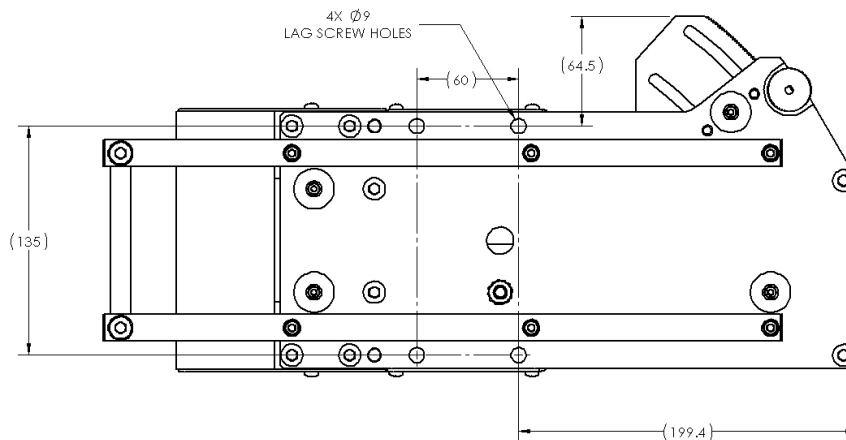

Dimensions are in millimeters

**5.7**

**SPECIFICATIONS**

Figure 5.2 Motor/Base Module Mounting Hole Locations



Hall Effect Sensor:

Supply Voltage: 4.5 To 24.5 VDC  
 Absolute Supply Voltage (max): -0.5 To 30.0  
 Supply Current (max): 18.5mA  
 Load Current: 25.0mA  
 Output Voltage "ON" (max): 0.0 To 0.4 VDC  
 Output Current "OFF" (max): 10.0uA

Motor General:

Step Motor: Nema Size 42  
 Step Angle: 1.8°  
 Insulation: UL Recognized Class B, 130° C  
 Protection Class: IP40 Minimum

Motor Electrical:

Bipolar  
 Per Phase Current: 5.5 AMPS  
 Per Phase Resistance: 1.16 OHMS  
 Per Phase Inductance: 7.8 mH

**5.8 MODEL NUMBER**

The model number provides important information about the specifics of your Motor/Base Module. Refer to this number when calling IVEK Technical support. The model number for your Motor/Base Module is located in the Title Page section of this manual.

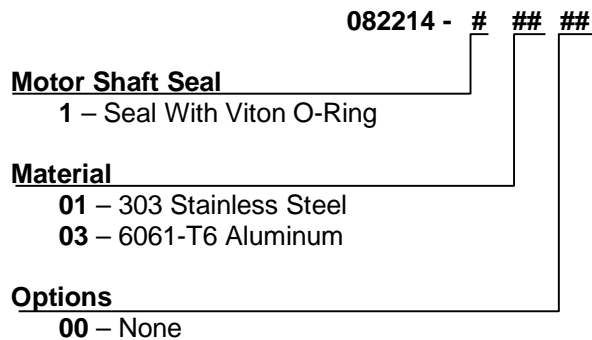

**5.9 ILLUSTRATED PARTS BREAKDOWN**

The Motor/Base Module contains no replaceable parts. Please contact IVEK Technical support for information regarding your system.