Table Of Contents

Section	Description	Page #
5.	Single End Microspense AP Motor/Base Module	5-2
5.1	Description	5-2
5.2	Operation	5-2
5.2.1	Indicator Tab	5-2
5.2.2	Displacement Adjustment	5-3
5.2.3	Auto Positioning	5-4
5.2.4	Fixed Displacement	5-5
5.2.5	Pump Stabilization.....	5-5
5.2.6	Spindle	5-8
5.2.7	Spindle Sensor	5-8
5.3	Installation	5-9
5.4	Options	5-9
5.4.1	DC Brushless Motor	5-10
5.4.2	High Torque Unipolar Motor	5-10
5.4.3	High Torque Bipolar Motor	5-10
5.4.4	120° Counter Clockwise Flag Adjustment	5-10
5.4.5	Displacement Adjustment With Micrometer	5-10
5.4.6	Displacement Adjustment With Digital Micrometer	5-10
5.5	Maintenance	5-10
5.5.1	Assembly/Disassembly Procedures	5-11
5.5.2	Indicator Tab Alignment	5-11
5.6	Problem Guide	5-11
5.7	Specifications	5-11
5.8	Model Number	5-12
5.9	Illustrated Parts Breakdown	5-12

5. SINGLE END MICROSPENSE AP MOTOR/BASE MODULE

5.1 DESCRIPTION (Figure 5.1)

The Single End Microspense AP Motor/Base Module, hereafter referred to as the Motor/Base Module, is comprised of the motor to drive a Pump Module, the base for support, the displacement adjustment mechanism and the cable with a connector. The stepper motor provides accurate control. The displacement adjustment mechanism changes the angle between the axis of the motor and the axis of the Pump Module piston thus changing the pumped volume. The cable connector provides a connection point for the cable from the Controller Module.

The Motor/Base Module measures 2.75" (69.9mm) wide, 4.83" (122.7mm) long and 4.24" (107.6mm) high with feet and weighs approximately 2.5 pounds (1.14 kilograms). Dimensions and weight listed are with no options.

5.2 OPERATION

The Motor/Base Module includes a thumbscrew for adjusting the calibration of the pump, a spindle rotation sensor and a drive spindle to move the piston. In dispensing operations, a dispense cycle consists of a specific number of revolutions. The Controller Module controls the number of revolutions. The volume per revolution is adjusted on the Motor/Base Module using the displacement adjustment thumbscrew.

5.2.1 Indicator Tab

A gauge is provided for reference when setting the Pump Module displacement. Setting the angle to "0" provides minimum output and "10" provides maximum output. The gauge is held in place by the thumb tab and slides under a plate mounted to the top of the Motor/Base Module.

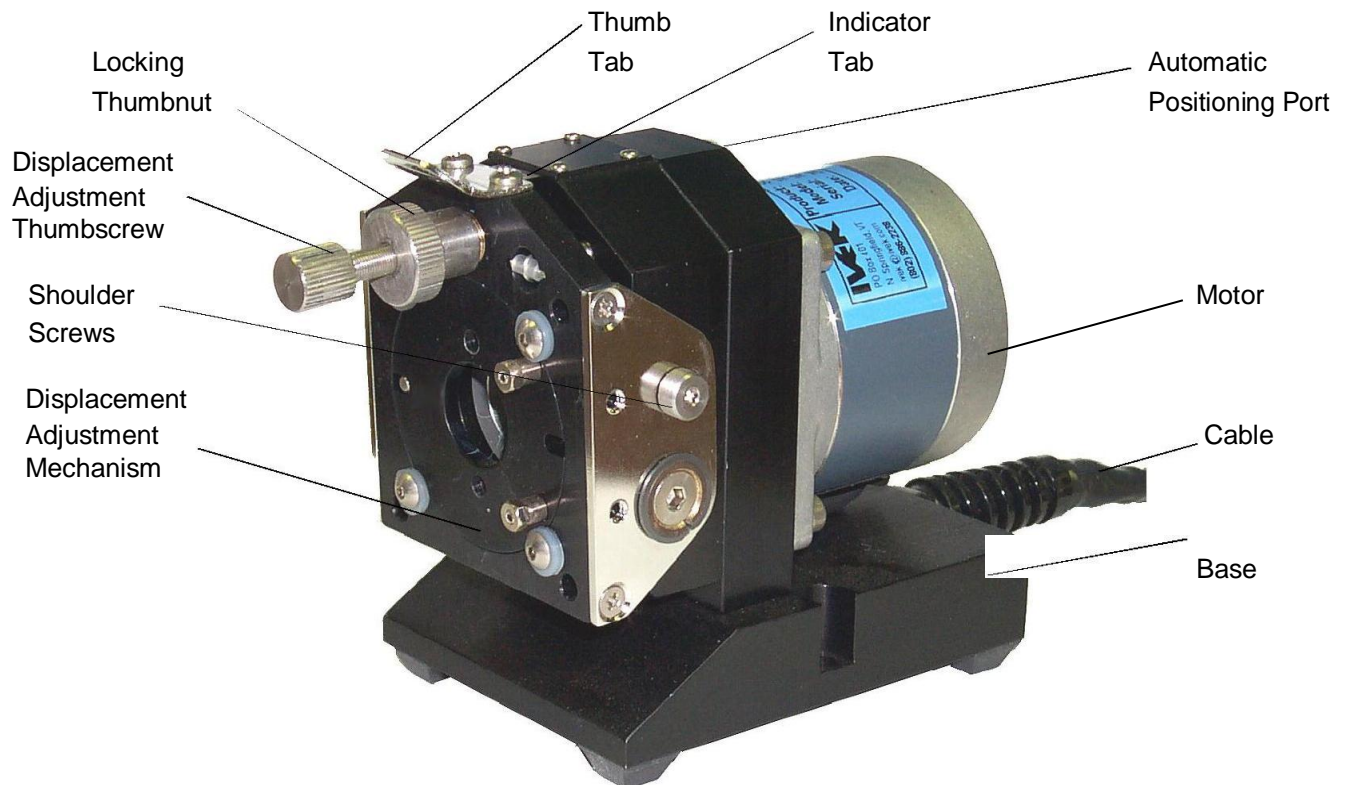

Figure 5.1 Single End Microspense AP Motor/Base Module

5.2.2 Displacement Adjustment (Figure 5.2)

The Motor/Base Module contains a two-position displacement adjustment mechanism. One position (maximum displacement) is used during priming and cleaning and the other position (calibrated displacement) is used during normal operation.

CAUTION

*If the piston is frozen in the cylinder, **do not** change the pump displacement either by auto positioning or depressing the thumb tab. Damage to the piston may result. Use the optional Pump Extractor Tool kit.*

To adjust the Motor/Base Module displacement for normal operation:

1. Loosen thumbnut (3)
2. Adjust angular position of displacement adjusting mechanism (1) by turning displacement adjustment thumbscrew (2). Turning the thumbscrew clockwise will increase the pump displacement. Turning the thumbscrew counter clockwise will decrease the pump displacement.
3. After verifying the pump displacement is correct, lock the thumbscrew (2) in place by tightening the thumbnut (3).

To adjust the Motor/Base Module for priming or cleaning:

CAUTION

The system must operate successfully in the dispense mode prior to applying air pressure to activate auto positioning. This prevents possible damage to the ceramic piston.

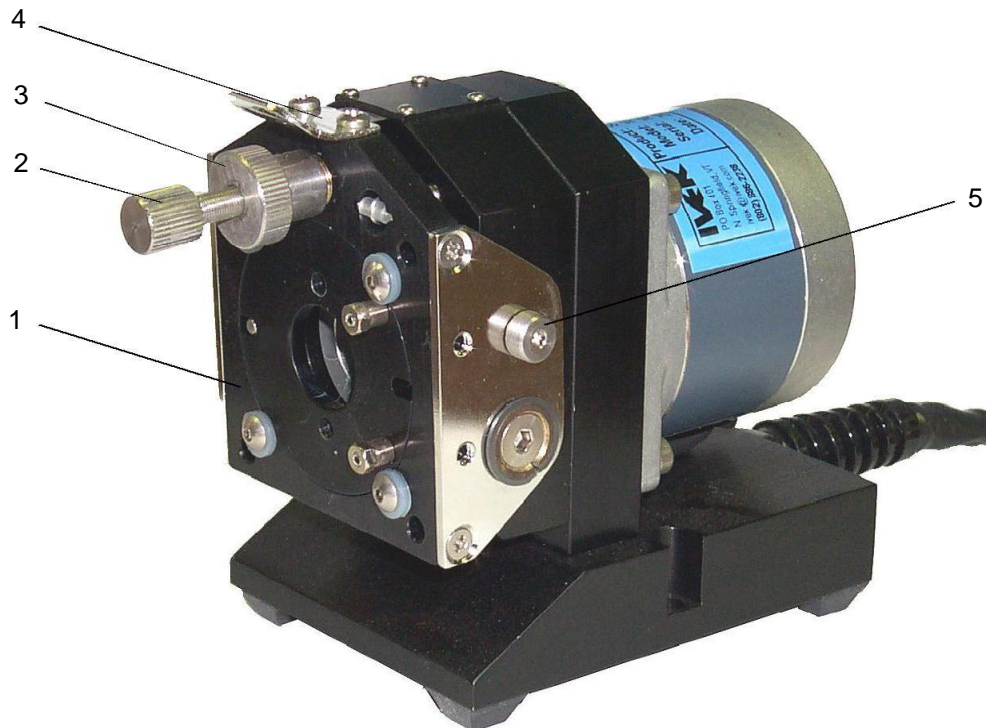

Figure 5.2 Single End Microspense AP Motor/Base Module Adjustment

NOTE

During this procedure, do not move the thumbnut (3) or displacement adjustment thumbscrew (2).

1. Press down on the thumb tab (4) (see Figure 5.3) to tilt the displacement adjustment mechanism (1) into its maximum displacement position.
2. While holding displacement adjustment mechanism (1) in its maximum displacement position, run the system in Prime mode.

After cleaning or priming is complete:

1. Slowly release the thumb tab (4) to allow the displacement adjustment mechanism to return to its calibrated position.

5.2.3 Auto Positioning

An Air inlet provides the ability to automatically position the Pump Module to change its displacement between the maximum and the calibrated setting. A #10-32 air in port can be connected to clean, oil free air at 80 PSI (5.5 Bar). We recommend installing an exhaust flow control valve in the air line either at the air in port or as close as possible.

CAUTION

The system must operate successfully in the dispense mode prior to applying air pressure to activate auto positioning. This prevents possible damage to the ceramic piston.

Pressing on thumb tab
opens up the displacement

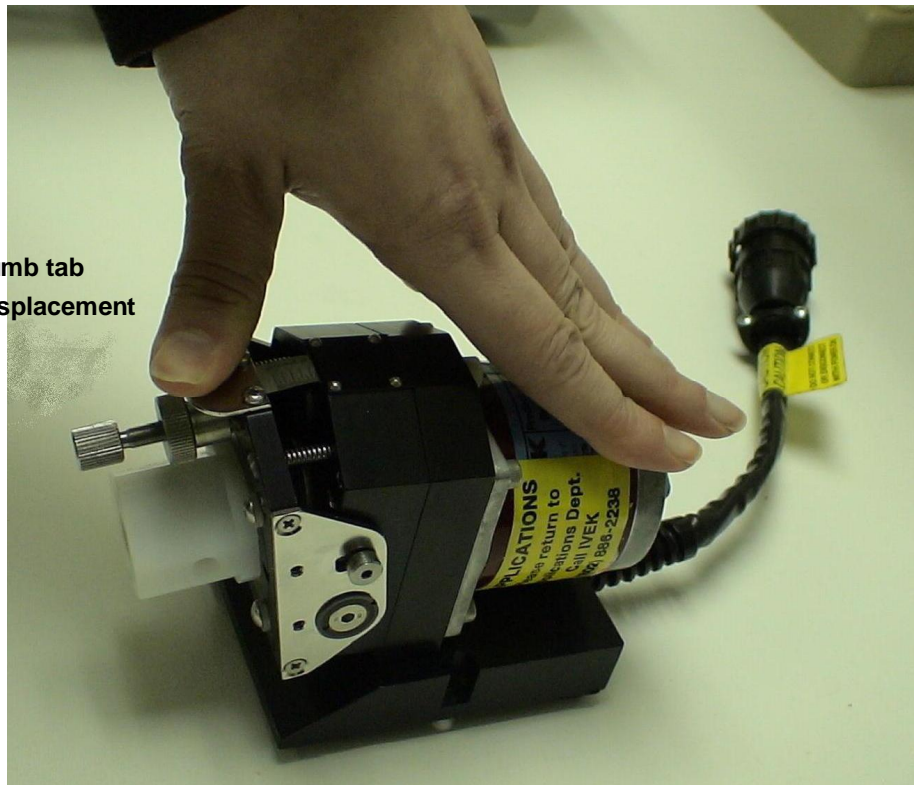

Figure 5.3

NOTE

If this option is used, verify the fixed displacement washers are not under the head of the two shoulder screws (Figure 5.2 Item 5) but, have been removed to allow the Pump Module displacement adjustment mechanism to pivot freely between the two positions.

When air is applied to the port, the Pump Module will be positioned for maximum displacement. When air is removed from the port, the Pump Module will return to its calibrated displacement position.

5.2.4 Fixed Displacement (Figure 5.2)

Fixed displacement is used when the displacement will not change for an extended period of time. To adjust the Motor Module displacement for fixed displacement:

1. Remove shoulder screws (5) from the Motor/Base Module.
2. Add two locking washers to screw (5) and replace. (do not tighten)
3. Loosen thumbnut (3) slightly.
4. Adjust angular position of displacement adjusting mechanism (1) by turning displacement adjustment thumbscrew (2). Turning the thumbscrew clockwise will increase the pump displacement. Turning the thumbscrew counter clockwise will decrease the pump displacement.
5. After verifying the pump displacement is correct, lock the thumbscrew (2) in place by tightening the thumbnut (3).
6. Tighten two shoulder screws (5) to lock the displacement adjustment mechanism in place.

5.2.5 Pump Stabilization (Figure 5.4)

Stabilization is a term used to describe the flow characteristics of the liquid being discharged at the tip or nozzle of a Microspense-AP liquid dispensing system. More specifically it is the manipulation of the displacement/time function of the piston and its relationship to the valve timing of the pump. A Microspense-AP can be adjusted to either *neutralize* or *accelerate* the discharge pulse of a system.

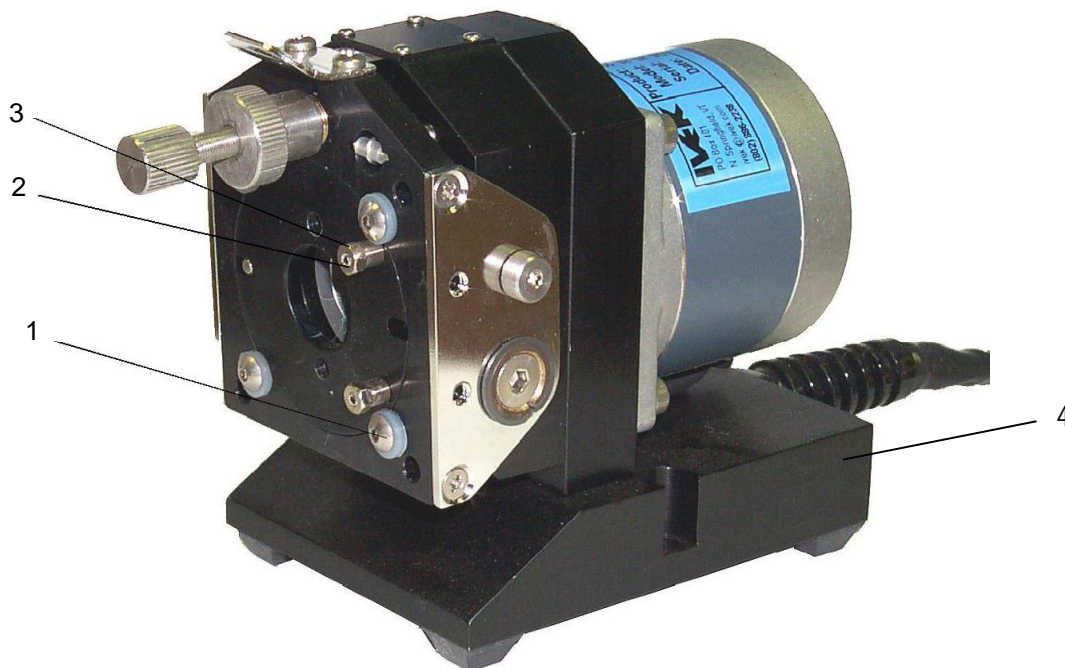

Figure 5.4 Microspense AP Motor/Base Module Pump Stabilization

This ability to stabilize the Microspense-AP can benefit the dispense characteristics of the pump in two ways. If the application requires a “touch off” of liquid from the dispense tip, neutralizing the discharge pulse will help in creating a uniform bead of liquid that will cling to the end of the tip or nozzle. In applications where it is more desirable to “fire off” a volume of liquid, accelerating the discharge pulse may enhance the ability to do this repeatedly with a clean liquid shear between each dispensed volume.

The pump stabilization adjustment is a feature that is used to fine tune the way liquid is separated from a dispensing tip. There are other aspects of the dispensing system which also effect this characteristic such as the rate of dispense, the tubing, and the dispense tip selection. The process of optimizing the dispensing operation includes experimentation with all of the variables until the desired result is achieved. When first experimenting with the pump stabilization feature, the user should start by adjusting the pump to a **neutral discharge** position (see 5.2.5.1). Once the user has determined that this position in combination with the other variables is not adequate, the **accelerated discharge** procedure (see 5.2.5.2) should be attempted for applications requiring the “fire off” dispense.

There are two #4-40 x .38" long socket set screws (2) located on the front of the Motor/Base Module (4) for adjusting the stabilization. These screws are used to “neutralize” the liquid output of the pump head or “accelerate” liquid at the end of the dispense cycle.

Tools required:

- 3/16 Open/Box End Wrench

NOTE

In most cases, IVEK dispensing systems are preset with pump heads stabilized before shipping. The following procedure is intended to aid the end user if, for example, the Motor/Base Module (4) is replaced or there is a change in dispensing modes.

After the stabilization set screws are adjusted, verify the dispense volume calibration because pump displacement is affected by this setting.

5.2.5.1 Adjusting For Neutral Discharge

The position of the Pump Module is adjusted with two set screws (2). Gently loosening and tightening these screws allows the user to move the Pump Module with precision. Do not overtighten the set screws.

The following steps describe the procedure for adjusting the pump module for neutral discharge. In general, a neutral position is established when the pump module stabilizing ring is flush with the face plate. In this position, the set screws (2) are not in contact with the face plate. (See Figure 5.5)

1. Prime the system as described in Chapter 2.
2. Loosen, do not remove, two stabilizing lock nuts (3) and back out (counterclockwise) the #4-40 x .38" long socket set screws (2) so they don't contact the Motor/Base Module (4).
3. Loosen, do not remove, four #6-32 x .31" Long Button Head Socket Cap Screws (1) then retighten evenly to 10 in-lbs.
4. Turn each #4-40 x .38" long socket set screw (2) clockwise until it seats and tighten its corresponding stabilizing lock nut (3). Do not exceed 5 in-lbs. of torque when tightening stabilizing lock nuts (3).

NOTE

A neutral dispense position can be verified by viewing the fluid as it is dispensed slowly from a clean translucent dispense tip (rate of “009” on the rate thumbwheel of the Controller Module). The fluid will flow in the forward direction in a smooth even fashion and then stop. When not properly stabilized to neutral, the liquid can move backwards either at the beginning or the end of the dispense.

5.2.5.2 Adjusting For Accelerated Discharge

When the Pump Module stabilizing ring is angled from flush mount (neutral position) on the discharge side the accelerated discharge characteristic is created.

The position of the Pump Module is adjusted with two set screws. Gently loosening and tightening these screws allows the user to move the Pump Module with precision. Do not overtighten the set screws.

The following steps describe the procedure for adjusting the Pump Module for accelerated discharge. In general, an accelerated discharge position is established when the pump module stabilizing ring is angled from the face plate. In this position, the setscrews (3) contact the face plate to create the angled position. These set screws can be adjusted to create a positive offset (0.04" (1.0mm) max.) between the pump module stabilizing ring and the face plate. (See Figure 5.4) The amount of fluidic acceleration is adjusted by changing this offset and can only be optimized through trial and error.

1. Prime the system as described in Chapter 2.
2. Loosen (1/4 turn) the two #6-32 x .31" long button head socket cap screws (1) on the discharge side of the Pump Module.
3. Loosen two stabilizing lock nuts (3) and turn #4-40 x .38" long socket set screws (2) until the set screw just touches the surface of the face plate.
4. Turn #4-40 x .38" long socket set screws (2) clockwise one additional turn.
5. Tighten two stabilizing lock nuts (3) in to lock the #4-40 x .38" long socket set screws (2) in place. Do not exceed 5 in-lbs. of torque when tightening stabilizing lock nuts (3).
6. Tighten two #6-32 x .31" long button head socket cap screws (1) to 10 in-lbs. (1.13 N-M) to lock the Pump Module stabilizing ring in position and fix the accelerated discharge adjustment.

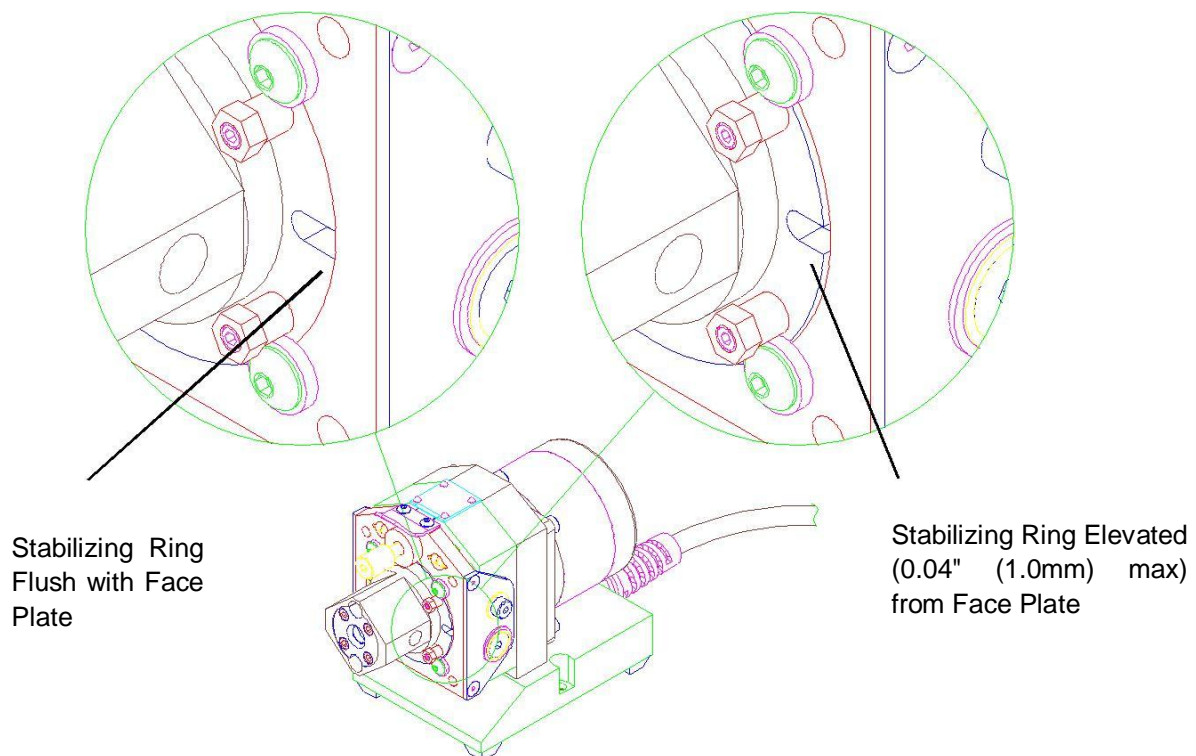

Figure 5.5 Stabilization Adjustment

7. Repeat steps 2 - 6 as necessary (do not exceed the 0.04" (1.0mm) maximum offset) until the desired amount of acceleration is achieved

NOTE

An accelerated dispense position can be verified by viewing the fluid as it is dispensed slowly from a clean translucent dispense tip (Select "Dispense" mode, set volume to "001" and rate to "009" ["040" on Multispense Controllers] on the Digispense Controller Module). The fluid will flow in the reverse direction before it moves forward out of the tip and stops. The amount of reverse motion will correspond to the degree of angular offset created by the set screws (0-0.04" (1.0mm) as measured from the face plate to the Pump Module stabilizing ring. Experimentation of all dispensing variables is required to optimize the accelerated discharge stabilization feature.

5.2.6 Spindle

A spindle, containing a spherical bearing, is mounted on the motor shaft. When the Pump Module is mounted with its drive pin inserted into the spherical bearing, the spindle drives the piston in a motion that combines rotation and reciprocation.

When the Pump Module is mounted on the Motor/Base Module, the pin extends through the center bore of the spherical bearing. At zero pump displacement, the axis of the piston aligns with the axis of the spindle and motor shaft. As the motor turns, the spindle drives the piston in a purely rotational motion. Introducing an angle between the axis of the spindle and the axis of the piston adds a reciprocating motion to the rotation of the piston. The magnitude of the reciprocating motion is a function (sinusoidal) of the angle between the axis of the piston and the axis of the spindle.

5.2.7 Spindle Sensor

A sensor, mounted on the Motor/Base Module, detects the rotation of the spindle, and is used to count revolutions, stop the pump during the intake stroke and detect stalls.

5.2.7.1 Volume Strokes

The spindle sensor allows the Controller Module to count the revolutions of the spindle to ensure the requested number of revolutions (volume strokes) have been completed. Just prior to reaching the required count, the sensor signals the stepper motor drive circuitry to decelerate.

5.2.7.2 Stopped Location

The Controller Module decelerates the motor and stops the spindle to position the piston during the intake stroke of the pump. The sensor signals the stepper motor drive circuitry to decelerate, thereby ensuring the position at the end of the dispense is based on a sensed position, and not on the accumulation of motion commands to the motor drive circuitry.

If the piston is at a random position, such as after reassembly due to cleaning, the spindle will be properly indexed to stop the piston during the intake stroke following the completion of the first dispense cycle (with no faults). By stopping during the intake stroke, variations in the exact stopping position will not affect dispense accuracy.

5.2.7.3 Stall Detect

Motor stalls are detected if a signal from the spindle sensor is not detected for each revolution commanded to the motor. In a stepping motor system, a stall has occurred if more than the 200 required steps for a revolution have been commanded without a subsequent signal from the spindle sensor. A small margin above 200 steps is allowed to prevent minor variations from incorrectly signaling a fault. If an error is detected, the system can be designed to

either inhibit further dispensing, alert the operator or provide a reject signal for integrated process control. In a brushless DC motor system, a timer is used in conjunction with the sensor to detect a stall. (Refer to Chapter 3 for more information)

5.3 INSTALLATION

The Motor/Base Module includes two clearance holes for #8-32 mounting screws. These holes can be used for mounting the Motor/Base Module onto various apparatuses. The orientation of the Pump Module should be considered when mounting the Motor/Base Module. Plan the mounting so the intake and discharge tubing and the Pump Module can be easily accessed. Additional consideration should be taken regarding the fluid flow and access to the locking screws if manual displacement adjustment will be required for priming and cleaning. Always keep the discharge of the Pump Module even with or higher than the intake and never mount the Motor/Base Module so the Pump Module's cylinder end cap faces upward. Refer to Figure 5.6 for the mounting hole locations. If mounting to a solid surface, remove the four rubber feet.

Some Motor/Base Modules are designed to work with certain Controller Modules as shown in the chart below. Make sure the Motor/Base Module is used with a compatible Controller Module. Please contact IVEK Corporation if there are any questions.

Model Number	Description	Multispense 900	Digispense 3009	Digispense 4000	Digispense 1000
102118-2###	Rare Earth Unipolar	Yes	Yes	Yes	No
102118-3###	Brushless DC	No	No	No	Yes
102118-4###	High Torque Unipolar	Yes	Yes	Yes	No
102118-5###	High Torque Bipolar	No	Yes	Yes	No

NOTE

If automatic positioning is to be used. Refer to the note in section 5.2.3 for additional instructions.

5.4 OPTIONS

IVEK Corporation offers a variety of options to best meet the customers' needs. Following is a list and description of available options for the Motor/Base Module. Refer to the Title Section of this manual for the list of options provided with this system.

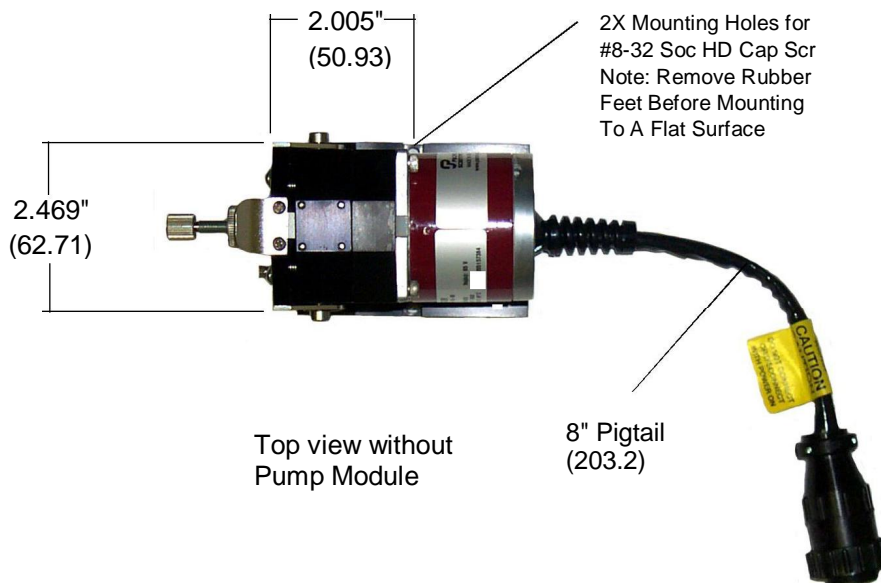

Figure 5.6 Single End Microspense AP Motor/Base Module Mounting Locations (Top View)

5.4.1 DC Brushless Motor

This option replaces the standard stepping motor with a DC brushless motor. The DC brushless motor provides higher speed and quieter characteristics.

IVEK Corporation provides application assistance in determining which motor works best for each application.

CAUTION

A stepping motor Controller Module cannot be used with a DC brushless Motor/Base Module. The opposite is also true.

5.4.2 High Torque Unipolar Motor

The High Torque Unipolar motor operates very similar to the Rare Earth Unipolar Motor and is a direct replacement, but has slightly different physical characteristics.

5.4.3 High Torque Bipolar Motor

The High Torque Bipolar Motor has been custom designed to decrease thermal losses in the motor and to flatten the speed-torque curve to provide higher torque at faster speeds relative to the unipolar motors. This connector on this is different than the other motor types.

5.4.4 120° Counter Clockwise Flag Adjustment

This option changes the stopped location of the piston and is used for specific conditions or fluids as recommended by our Applications Department.

NOTE

The 120° Counter Clockwise Flag Adjustment can only be used on Multispense and 3009 Controller Modules and not with a Brushless DC motor.

5.4.5 Displacement Adjustment With Micrometer (Figure 5.8 Item 14)

This option replaces the standard displacement adjustment and allows for more precise control. Adjust angular position of displacement adjusting mechanism by turning the micrometer adjustment mechanism.

5.4.6 Displacement Adjustment With Digital Micrometer (Figure 5.8 Item 15)

This option replaces the standard displacement adjustment and allows for more precise control and a digital display. Adjust angular position of displacement adjusting mechanism by turning the micrometer adjustment mechanism.

5.5 MAINTENANCE

Minimal maintenance is necessary for this Motor/Base module. Refer to Chapter 7 for the piston fabrication lubricating instructions.

CAUTION

Never connect or disconnect the cable from the Motor/Base Module connector while power is on. Damage to the equipment may result.

5.5.1 Assembly/Disassembly Procedures

Refer to Chapter 7 for the Pump Module assembly/disassembly procedures.

5.5.2 Indicator Tab Alignment (Figure 5.7)

The indicator tab requires alignment if replaced or removed. To align the indicator tab;

1. Prepare the system for operation. (Refer to Chapter 2)
2. Prime the system. (Refer to Chapter 3)

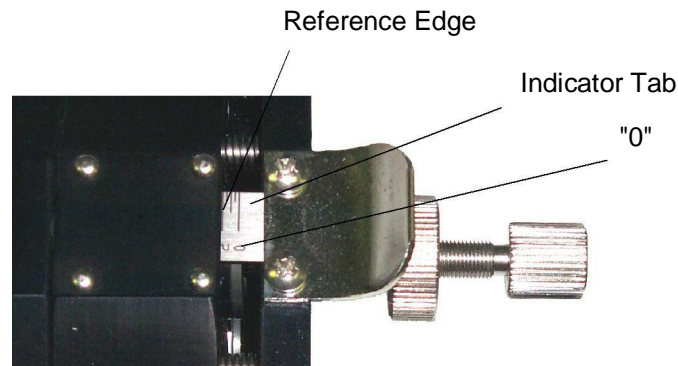

Figure 5.7 Indicator Tab Alignment

3. Set the displacement so there is no forward or reverse liquid flow.
4. Loosen the two button head cap screws securing the thumb tab to the Motor/Base Module.
5. Set the scale so "0" is aligned to the reference edge.
6. Alternately and evenly tighten the two button head cap screws securing the thumb tab to the Motor/Base Module.

5.6 PROBLEM GUIDE

Table 5.1 contains a list of possible problems, causes and solutions for the Motor/Base Module.

5.7 SPECIFICATIONS

Hall Effect Sensor:	Supply Voltage:	4.5-24 VDC
	Supply Current:	8.5mA
	Output Voltage:	0.4 VDC Open Collector Output Signal
	Output Current:	20mA

5.8 MODEL NUMBER

The model number provides important information about the specifics of your Motor/Base Module. Refer to this number when calling IVEK Technical support. The model number for your Pump Module is located in the Title Page section of this manual.

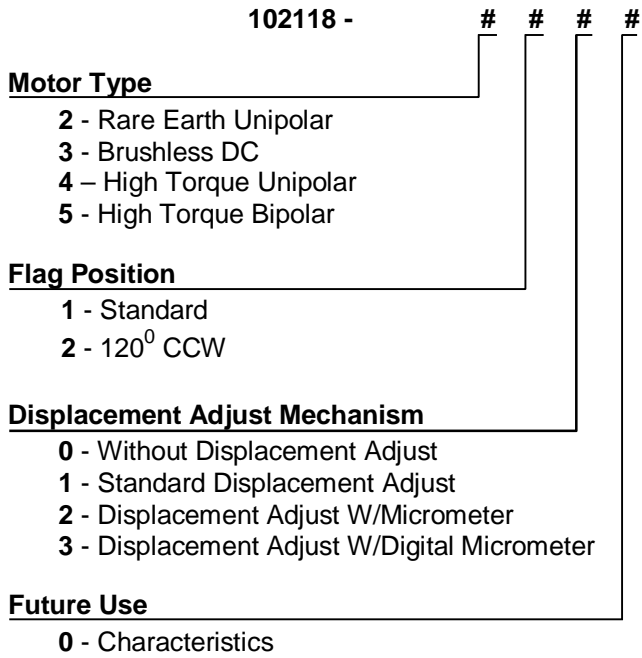

5.9 ILLUSTRATED PARTS BREAKDOWN

The illustrated parts breakdown (Figure 5.8) contains the information required for identifying and ordering replacement parts.

Table 5.1 Common Operational Problems And Solutions

PROBLEM	PROBABLE CAUSE	POSSIBLE SOLUTION
<p>Power is on, Controller Module accepts trigger, motor spindle fails to rotate and motor makes a sound that fluctuates in tone. * This condition does not harm the system.</p>	<p>Pump Module piston is binding.</p>	<p>Turn off Controller Module power. ** Remove Pump Module from Motor/Base Module. Do not try to free the Pump Module by changing the displacement. (See Caution in section 5.2.2) Turn on Controller Module and try again. If the motor operates correctly, the Pump Module may need to be cleaned or serviced.</p>
<p>Controller Module power on and operational, but will not actuate Motor/Base Module.</p>	<p>Controller cable</p>	<p>Turn off Controller Module power. Remove, inspect and reconnect cable between Controller Module and Motor/Base Module. Inspect for faulty cable.</p>
<p>Power is on, Controller Module accepts a trigger, (START indicator illuminates, STOP indicator does not), motor spindle fails to rotate, and motor is silent.</p>	<p>Improper motor cable connection or motor malfunction.</p>	<p>Turn off Controller Module power. Remove, inspect and reconnect cable between Controller Module and Motor/Base Module. Turn on Controller Module and try again. If the motor operates incorrectly, servicing may be necessary to the motor or the controller. Return complete Controller, Motor/Base and Pump Modules to IVEK Corporation for repair.</p>
<p>Motor turns 3 times, stalls and repeats.</p>	<p>Sensor problem</p>	<p>Contact IVEK technical support for assistance.</p>
<p>Displacement adjustment thumbscrew does not operate smoothly.</p>	<p>Dirt on threads Threads damaged</p>	<p>Clean. Contact IVEK technical support for assistance.</p>
<p>Pump Module mounting plate does not pivot.</p>	<p>Lock washer installed and shoulder screw too tight or side plate damaged</p>	<p>Remove washers and loosen shoulder screw, if already loose, inspect side plate for damage, replace if necessary.</p>

** If the Pump Module piston is seized, restricting its removal, refer to the instructions provided with the optional Pump Extractor Tool Kit - IVEK Part # 072087.

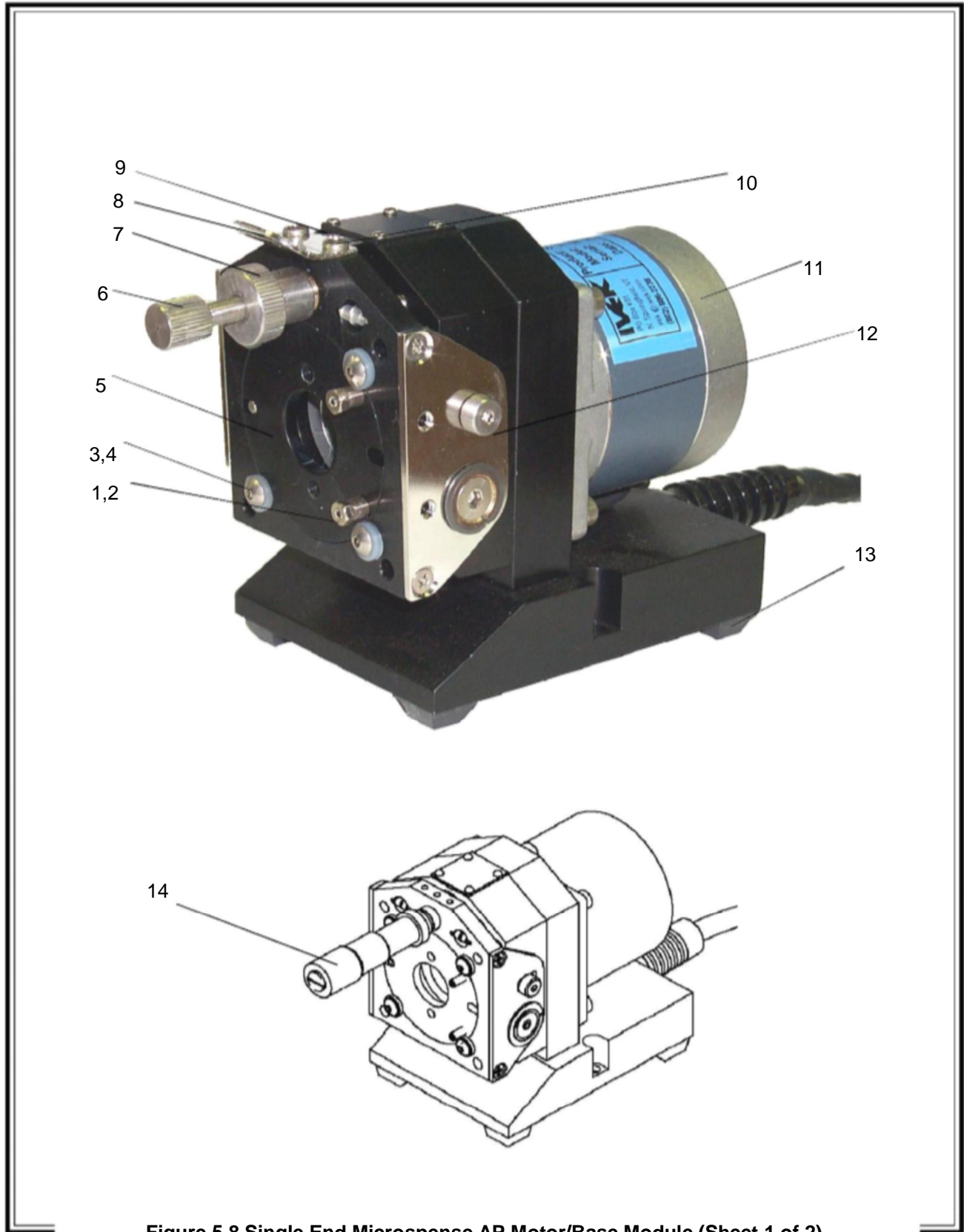

Figure 5.8 Single End Microspense AP Motor/Base Module (Sheet 1 of 2)

	PART NUMBER	DESCRIPTION	UNITS PER ASSY
	102118-####	Motor/Base Module, Microspense-AP, SGL End	1
Model Dwg			
#	Index	Part	
Tab	#	#	Description Qty
	13	092181-01R	Rubber Feet 4
102118 - # # # # MOTOR TYPE			
2	11	800003-01R	Motor, 23 Frame, Step, RE, SE; Char 1, RoHS 1
3	11	800004-01R	Motor, 23 Frame, Brushless DC, Single End; Char 01, RoHS 1
4	11	800059-01	Motor, 23 Fr Step, High Torque, SE, Sty 4, Char 01 1
5	11	800045-01	Motor, 23 Fr Step, High Torque, SE, Sty 3, Char 01 1
102118 - # # # # Displacement Adjust Mechanism			
1,2,3	1	102128	Stabilizing Lock Nut 2
1,2,3	2	182018-C04038	#4-40 x 3/8" Long Socket Set Screw 2
1,2,3	3	072090-001	Nylon Spacer 4
1,2,3	4	182005-C06031	#6-32 x .31" Long Button Head Socket Cap Screw 4
1,2,3	5	102117	Stabilizing Ring 1
1	6	102175	Thumb Screw Fabrication 1
1	7	102174	Thumb Nut 1
1	8	102154	Thumb Plate 1
1	9	102165	Indicator Tab 1
1,2	10	182030-C04025	#4-40 x .25" Lg Phillips Pan Head Screw 2
1,2,3	12	102095-001	Shoulder Screw 2
2	14	102243	Micrometer Modification Displacement Adjust 1
3	15	102283	Micrometer Head, 0-25mm, Digital Micrometer Adjust 1

DIGITAL MICROMETER 15

Figure 5.8 Single End Microspense AP Motor/Base Module (Sheet 2 of 2)