

---

**Table Of Contents**

---

<b>Section</b>	<b>Description</b>	<b>Page #</b>
<b>5.</b>	<b>Single End Standard Motor/Base Module .....</b>	<b>5-2</b>
5.1	Description .....	5-2
5.2	Operation .....	5-2
5.2.1	Adapter Pointer .....	5-3
5.2.2	Spindle Sensor .....	5-4
5.2.3	Spindle .....	5-4
5.3	Installation .....	5-5
5.4	Options .....	5-6
5.4.1	Double/Triple Stack .....	5-6
5.4.2	Direct Micrometer Adjust .....	5-7
5.5	Maintenance .....	5-7
5.6	Problem Guide .....	5-8
5.7	Specifications .....	5-8
5.8	Illustrated Parts Breakdown .....	5-8

## 5. SINGLE END STANDARD MOTOR/BASE MODULE

### 5.1 DESCRIPTION (Figure 5.1)

The Single End Standard Motor/Base Module, hereafter referred to as the Motor/Base Module, is comprised of the motor to drive the Pump Module, the base to support the Pump Modules and one cable with connector. The motor provides accurate control. The displacement adjustment mechanisms change the angle between the axis of the motor and the axis of the Pump Module thus changing the pumped volume. The cable and connector provides for connection to the Controller Module.

The Motor/Base Module measures 3.380" (85.6mm) wide, 8.268" (210.0mm) long and 4.093" (104.0mm) high (see Figure 5.3) without feet and weighs approximately 7 pounds (15.4 kilograms). Dimensions and weights listed are with no options. A description of the operation of a Pump Module on the Motor/Base Module is located in Chapter 7.

### 5.2 OPERATION

The Motor/Base Module includes two thumb nuts for securing an Adapter Pointer (Figure 5.2) to the Motor/Base Module, a spindle rotation sensor and a drive spindle to move the piston.

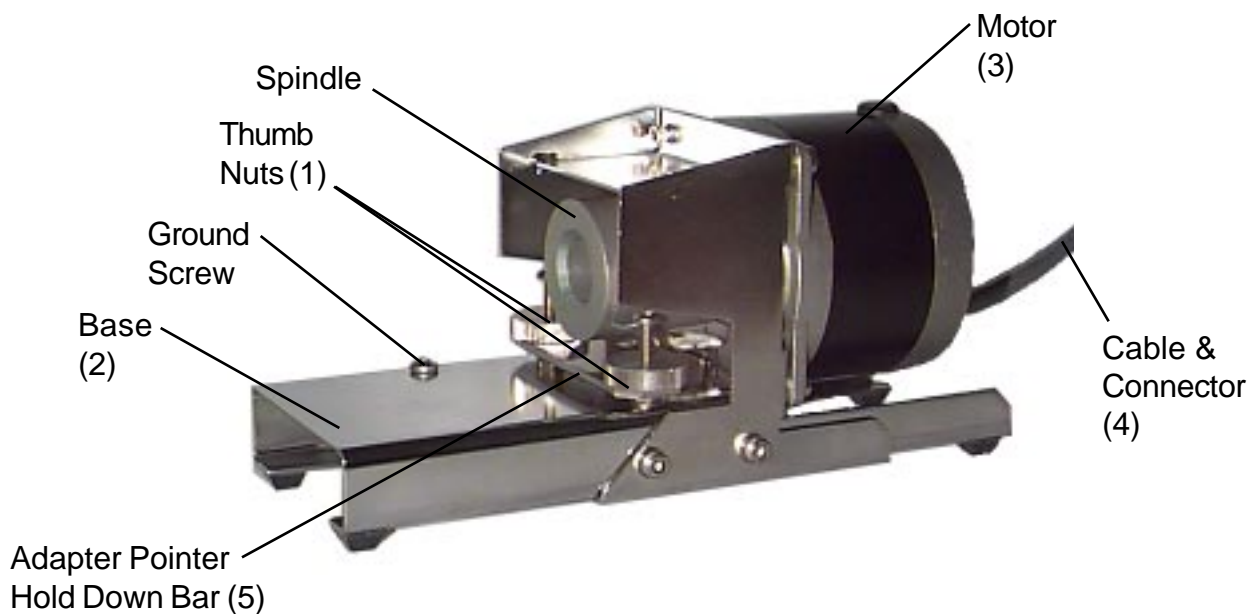

**Figure 5.1 Single End Standard Motor/Base Module**

### 5.2.1 Adapter Pointer (Figure 5.2)

The Adapter Pointer is used to change the angular relationship of the Pump Module axis to the drive spindle axis. The greater the angle, the greater the volume of liquid displaced for each revolution.

The Pump Module mounts on the adapter pointer and is secured using the two mounting screws.

To mount the adapter pointer to the Motor/Base Module (Figure 5.1):

1. Loosen the thumbnuts (1).
2. Slide the Adapter Pointer under the hold down bar (5).
3. Place the pin on the adapter pointer into the pivot hole located under the hold down bar (5).
4. Alternately tighten the thumb nuts (1). (finger tighten only)

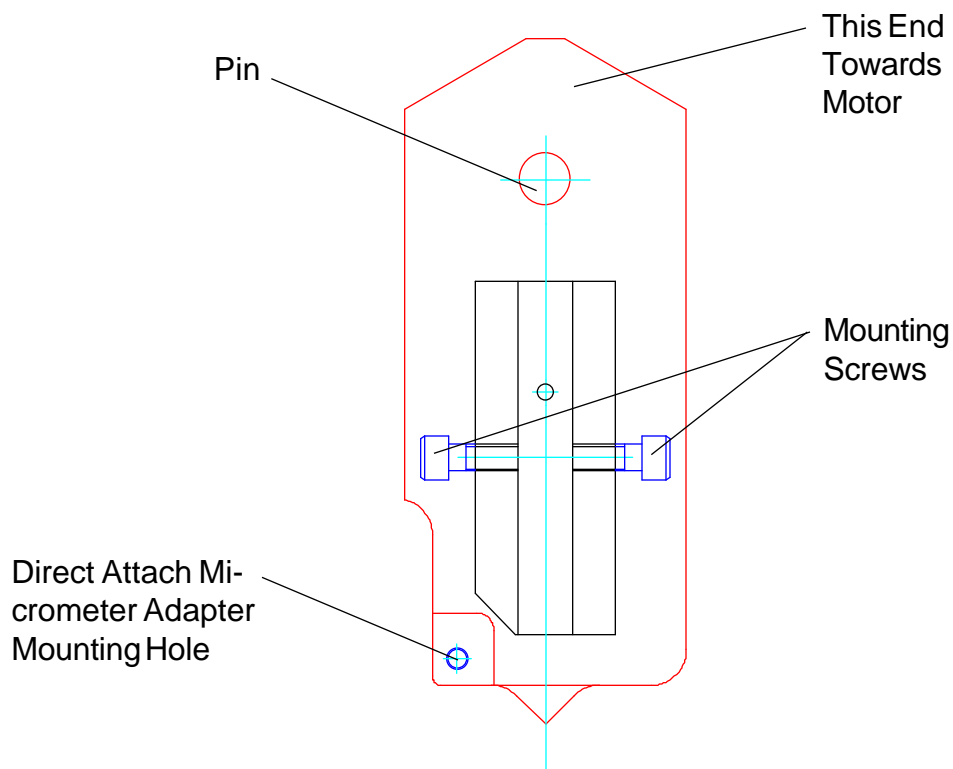

Figure 5.2 Adapter Pointer

## **5.2.2 Spindle Sensor**

A sensor detects the rotation of the spindle, and is used to count revolutions, stop the pump during the intake stroke and detect stalls.

### **5.2.2.1 Volume Strokes**

The spindle sensor allows the Controller Module to count the revolutions of the spindle to ensure the requested number of revolutions (volume strokes) has been completed. Just prior to reaching the required count, the sensor signals the stepper motor drive circuitry to decelerate.

### **5.2.2.2 Stopped Location**

The Controller Module decelerates the motor and stops the piston during the intake stroke of the pump. The sensor signals the stepper motor drive circuitry to decelerate, thereby insuring the position at the end of the dispense is based on a sensed position, and not on the accumulation of motion commands to the motor drive circuitry.

If the piston is at a random position, such as after reassembly due to cleaning, the piston will be properly indexed to stop during the intake stroke following the completion of the first dispense cycle (with no faults). By stopping during the intake stroke, variations in the exact stopping position will not affect dispense accuracy.

### **5.2.2.3 Stall Detect**

Motor stalls are detected if a signal from the spindle sensor is not detected for each revolution commanded to the motor. In a stepping motor system, a stall has occurred if more than the 200 required steps for a revolution have been commanded without a subsequent signal from the spindle sensor. A small margin above 200 steps is allowed to prevent minor variations from incorrectly signaling a fault. If an error is detected, the system can be designed to either inhibit further dispensing, alert the operator or provide a reject signal for integrated process control. (Refer to Chapter 3 for more information)

## **5.2.3 Spindle**

A spindle, containing a spherical bearing, is mounted on each motor shaft. When a Pump Module is mounted with its drive pin inserted into the spherical bearing, the spindle drives the piston in a motion that combines rotation and reciprocation.

When a Pump Module is mounted on the Motor/Base Module, the piston pin extends through the center bore of the spherical bearing. At zero pump displacement, the axis

of the piston aligns with the axis of the spindle and motor shaft. As the motor turns, the spindle drives the piston in a purely rotational motion. Introducing an angle between the axis of the spindle and the axis of the piston adds a reciprocating motion to the rotation of the piston. The magnitude of the reciprocating motion is a function (sinusoidal) of the angle between the axis of the piston and the axis of the spindle.

**5.3 INSTALLATION**

The Motor/Base Module has four rubber feet for mounting onto a flat surface. Optional mounting brackets provide four mounting holes (Refer to Figure 5.3). These four mounting holes can be used for mounting onto various apparatuses.

The orientation of the Pump Module should be considered when mounting the Motor/Base Module. Plan the mounting so the intake and discharge tubing and the end cap which holds the Pump Module's cylinder in place can be easily accessed. Additional consideration should be taken regarding the fluid flow. Always keep the discharge of

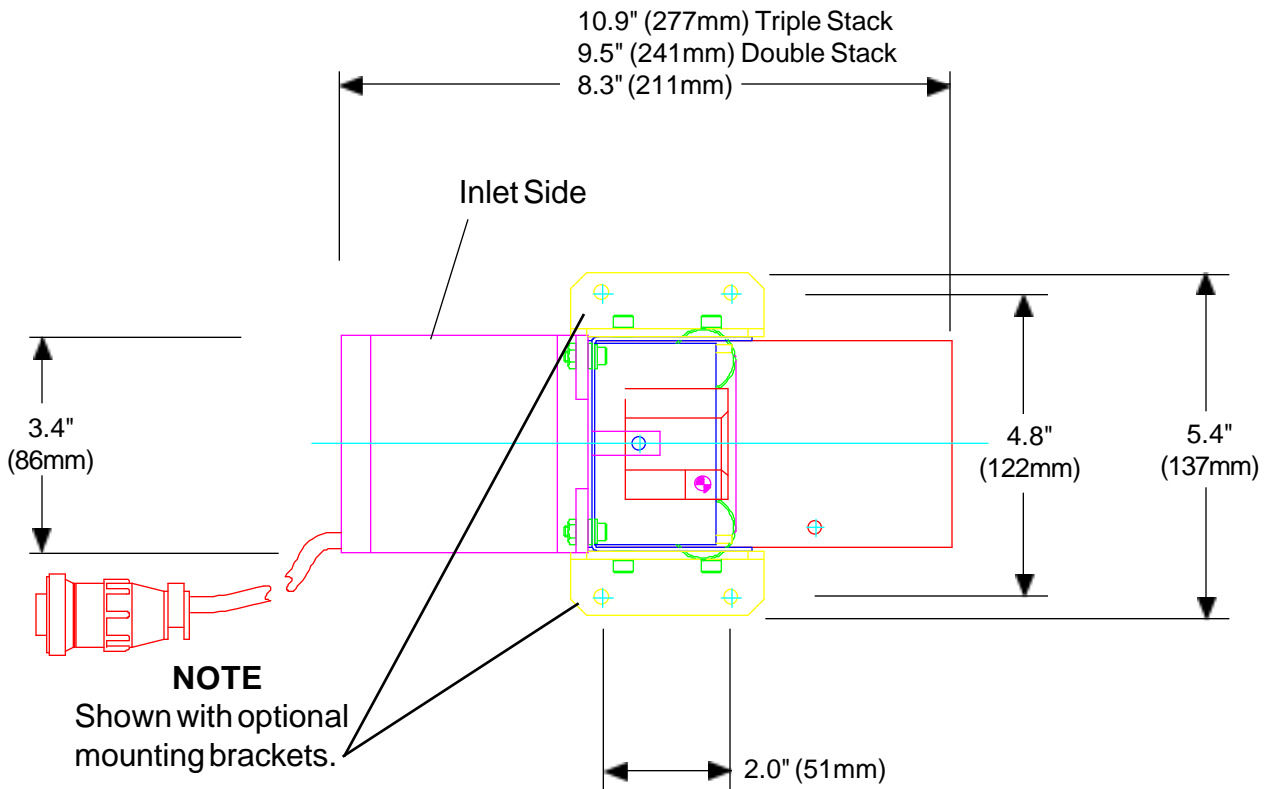

**Figure 5.3 Single End Standard Motor/Base Module Dimensions**

the Pump Module even with or higher than the intake and never mount the Motor/Base Module so either Pump Module's cylinder end cap faces upward. Refer to Figure 5.3 for the mounting hole locations. If Mounting to a solid surface, remove the rubber feet.

Some Motor/Base Modules are designed to work with certain Controller Modules. Make sure the Motor/Base Module is used with the Controller Module with which it was shipped or a comparable model. Please contact IVEK Corporation if there are any questions.

## **5.4 OPTIONS**

IVEK Corporation offers a variety of options to best meet the customers needs. Following is a list and description of available options for the Motor/Base Module. Refer to the Title Section of this manual for the list of options provided with this system.

### **5.4.1 Double/Triple Stack**

These options provide increased motor torque as needed to pump higher density liquids or against varying output pressures. A double or triple stack stepper motor is used depending on the specific application.

IVEK Corporation provides application assistance in determining which motor works best for each application.

#### **CAUTION**

*The Controller Module must be adjusted at the factory when changing between Motor/Base Modules with different stack sizes. An incorrect match between the Controller Module and the Motor/Base Module may result in reduced motor torque or equipment damage.*

**5.4.2 Direct Micrometer Adjust (Figure 5.4)**

The direct micrometer adjust option is used for precise pump calibration. The micrometer moves the adapter pointer (section 5.2.1) for fine tuning the Pump Module's displacement. The dial on the micrometer provides a precise reference when setting the pump's displacement. If the pump displacement is changed, just return to the reference. Minor adjustments may still be necessary.

**5.5 MAINTENANCE****CAUTION**

Never connect or disconnect the cable from the Motor/Base Module connector while power is on. Damage to the equipment may result.

Refer to Chapter 7 for the piston fabrication lubricating instructions.

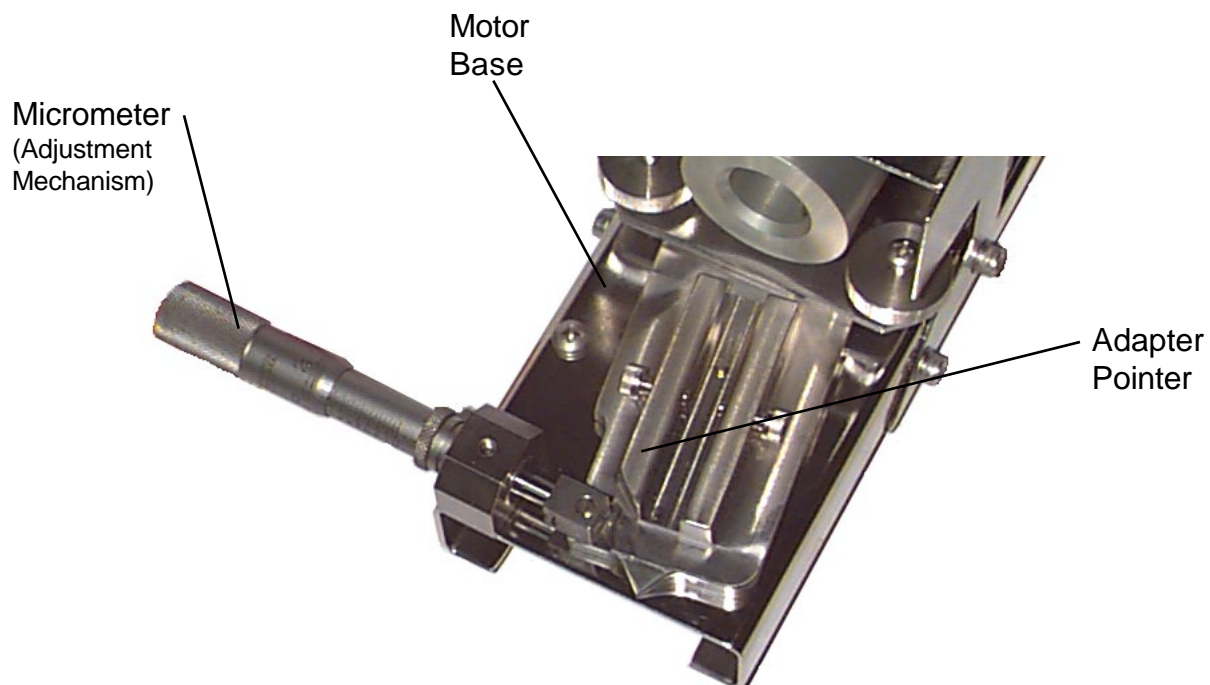

**Figure 5.4 Micrometer Adjust**

**5.6 PROBLEM GUIDE**

Table 5.1 contains a list of possible problems, causes and solutions for the Motor/ Base Module.

**5.7 SPECIFICATIONS**

Hall Effect Sensor:	Supply Voltage	6-24 VDC	
	Supply Current	13mA	
	Output Voltage	0.4 VDC	Open Collector Output Signal
	Output Current	20mA	

**5.8 ILLUSTRATED PARTS BREAKDOWN**

The illustrated parts breakdown (Figure 5.5) contains replacement parts for this Motor/Base Module.



Table 5.1 Common Operational Problems And Solutions

PROBLEM	PROBABLE CAUSE	POSSIBLE SOLUTION
<p>Power is on, Pump Module is mounted, Controller Module accepts trigger, but the motor spindle fails to rotate and motor makes a sound that fluctuates in tone. * This condition does not harm the system.</p>	<p>Motor spindle binding.</p>	<p>Turn off Controller Module power. Remove Pump Modules from Motor/Base Module. Inspect and verify the Pump Module pistons are moving freely. Turn on Controller Module and try again.</p> <p>If the motor operates correctly, the Pump Module may need to be cleaned or serviced.</p> <p><b>If none of the above solves the problem, contact IVEK technical support for assistance.</b></p>
<p>Power is on, Controller Module accepts a trigger, (START indicator illuminates, STOP indicator does not), motor spindle fails to rotate, and motor is silent.</p>	<p>A motor malfunction can cause this problem.</p>	<p>Turn off Controller Module power. Check to ensure Motor/Base Module is properly connected to Controller Module. Turn on Controller Module and try again. If the motor operates incorrectly, servicing may be necessary to the motor or the controller. Return complete Controller, Motor/Base and Pump Modules to IVEK Corporation for repair.</p>
<p>Controller Module power on and operational, but will not actuate Motor/Base Module.</p>	<p>Controller cable</p>	<p>Check connection of cable between Controller Module and Motor/Base Module. Inspect and replace faulty cable.</p>
<p>Motor turns 3 times, stalls and repeats.</p>	<p>Sensor problem</p>	<p>Contact IVEK technical support for assistance.</p>

INDEX NO.	PART NUMBER	DESCRIPTION	UNITS PER ASSY
	<b>092158</b>	<b>Single End Standard Motor/Base Module</b>	<b>1</b>
1	01311-1	Hold Down Bar	1
2	092142	Split Case Adapter Pointer Base	1
3	092128	Rubber Foot	4
4	092170	Thumb Nut	2
5	----	8-32 Hex Nut (18-8)	4
6	----	8-32 x 1.25" But Hd Mach Screw (18-8)	2
<b>Options</b>			
	092180	Micrometer, Direct	1
	092169	Micrometer Mount, Direct Adjust	1
	092157	Mounting Bracket	2

Figure 5.5 Single End Standard Motor/Base Module (Sheet 1 of 1)